

# Pathfinder Radar/Chartplotter Series Service Manual

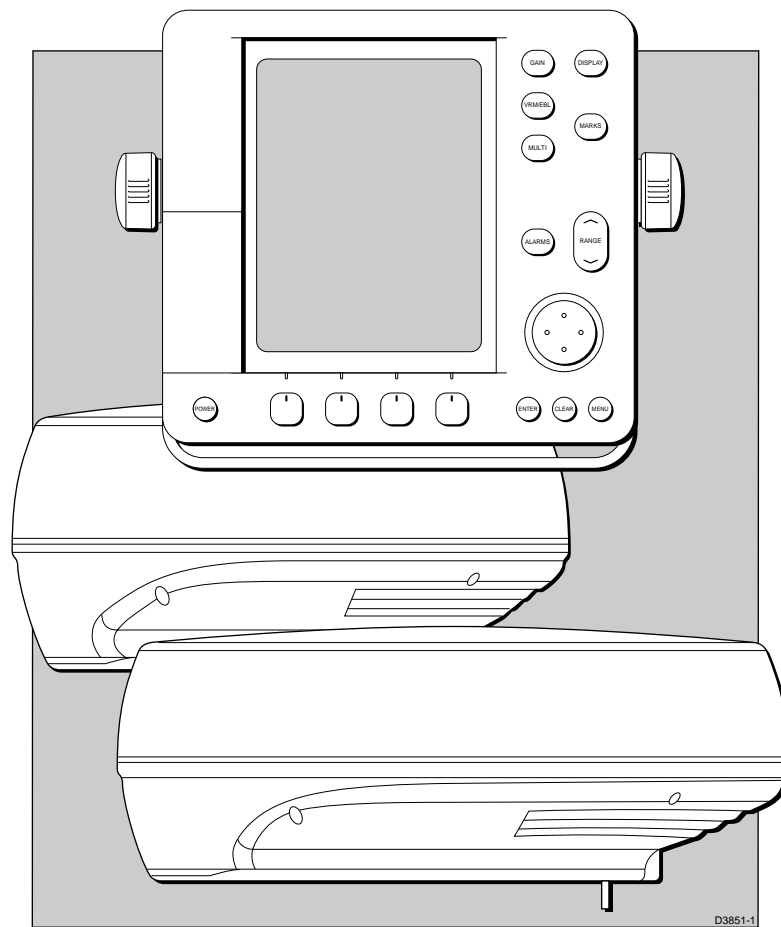

## Part 2 - Radome Scanner Units

Document No: 83139

### Warning

#### CE Marking of Equipment/Replacement Parts

If the Raytheon/Autohelm equipment under repair, test, calibration, installation or setting to work carries the European CE mark, only parts and components supplied or approved for such use by Raytheon should be used in order to maintain compliance with the relevant CE requirements.

Incorporation, use or attachment, by any means, of parts or components not supplied for or not approved for such use by Raytheon or, if supplied or approved for use by Raytheon, not properly fitted in accordance with instructions published, provided or recommended by Raytheon, may cause the equipment to malfunction and, in particular, to become unsafe or to no longer meet the relevant CE requirements. In these circumstances, Raytheon Marine Company excludes liability to the fullest extent permissible in law for any loss or damage including any liability for its contribution to such loss or damage by its negligent acts or omissions.

# Safety Notices

This radar/chartplotter equipment must be installed and operated in accordance with the instructions contained in the Owner's Handbook. Failure to do so can result in personal injury and/or navigational inaccuracies. In particular:

## 1. High Voltage



The radar scanner unit contains high voltages. The radar should always be turned off before removing the covers. The scanner unit high voltage can take up to 1 minute to decay. The specialised service procedures should only be carried out by qualified service technicians.

## 2. Electromagnetic Energy



The radar scanner transmits electromagnetic energy. It is important that the radar is turned off whenever personnel are required to come close to the scanner to perform work on the scanner assembly or associated equipment.

It is recommended that the radar scanner is mounted out of range of personnel (above head height).

Avoid looking directly at the antenna as your eyes are the most sensitive part of the body to electromagnetic energy.

When properly installed and operated, the use of this radar will conform to the requirements of ANSI / IEEE C95.1-1992 Standard for Safety Levels with Respect to Human Exposure to Radio Frequency Electromagnetic Fields, 3Hz to 300 GHz.

## 3. Magnetron

Persons with cardiac pacemakers must not engage in service or preventative maintenance of the radar, in close proximity to the magnetron. There is danger of abnormal operation of cardiac pacemakers.

## 4. Navigation Aid

This radar unit is only an aid to navigation. Its accuracy can be affected by many factors, including equipment failure or defects, environmental conditions, and improper handling or use. It is the user's responsibility to exercise common prudence and navigational judgements. This radar unit should not be relied upon as a substitute for such prudence and judgement.

# Warranty

When a repair is carried out by an authorised Raytheon service representative, some or all of the cost may be covered by the Raytheon warranty. Refer to the Limited Warranty Certificate reproduced for guidance at the beginning of **Part 1**.

# Contents

- Chapter 1. Introduction ..... 1**
- Chapter 2. Technical Description ..... 3**
  - 2.1 Overview ..... 3
    - Scanner configuration ..... 3
    - Receiver configuration (LNC/IF) ..... 4
    - Low Noise Converter/Limiter (LNC) ..... 4
  - 2.2 Modulator / PSU – Interface Description ..... 6
    - Connectors ..... 6
    - Ship Supply Power Input (CN1) ..... 6
    - PSU Control/Status (CN2) ..... 6
    - Modulator Control/Status (CN2) ..... 6
    - Motor Control ..... 7
    - Ships Heading Interface ..... 7
    - Receiver Power Supply ..... 7
    - Stepper Motor Interface ..... 7
    - Ships Heading Sensor Opto-coupler Interface ..... 7
    - Magnetron Interface ..... 8
  - 2.3 Modulator / PSU – Circuit Description ..... 8
    - Design Overview ..... 8
    - Circuit Description ..... 9
      - EMC Filter ..... 9
      - Over Voltage Protection ..... 9
      - Supply Reversal Protection ..... 9
      - DC-DC1 and Start / Shutdown Circuit ..... 9
        - Scanner operating supply voltage range ..... 9
        - Output Specification DC-DC1 ..... 10
      - DC-DC2 ..... 10
        - Output Specification DC-DC2 ..... 10
    - Modulator ..... 11
    - Modulator Clock, PRI\_PLS ..... 12
    - Ships Heading Sensor ..... 12
    - Stepper Motor Controller ..... 12
  - 2.4 IF Receiver PCB – Interface Description ..... 12
    - Connectors ..... 12
    - Display Connector (SK1) ..... 13
    - LNC Connector (P1) ..... 14
    - Mod / IF Interconnect (P4) ..... 14

Part 2  
Preface

|  |           |
|--|-----------|
| 2.5 IF Receiver – Circuit Description .....  | 14        |
| Main Receiver .....  | 14        |
| Summary of bandwidths, pulse widths and PRI rates .....  | 15        |
| Autotune Receiver .....  | 15        |
| STC/Main Bang Suppression (MBS) .....  | 15        |
| Microcontroller .....  | 16        |
| Initial Scanner set up (EEPROM stored values) .....  | 16        |
| 2.6 Antenna / Rotary Joint Assembly .....  | 17        |
| 2.7 Scanner Display Connection .....   | 18        |
| <b>Chapter 3. Fault Finding .....</b>  | <b>19</b> |
| 3.1 Safety Notices .....   | 19        |
| 3.2 General Notes .....  | 19        |
| 3.3 Built-in Testing / Diagnostics .....   | 20        |
| 3.4 Master and Repeater LCD Displays .....   | 20        |
| 3.5 Check Lists .....  | 21        |
| Check List 2 .....   | 21        |
| Scanner Not Responding message displayed or Start-up countdown restarts unexpectedly .....             | 21        |
| External Checks .....  | 21        |
| Display Circuit Operation .....  | 22        |
| Display Internal Checks .....  | 22        |
| Display Check 1 - Display has no power at scanner plug at rear of display .....                        | 22        |
| Display Check 2 - Display communications check .....   | 23        |
| Display Check 3 - Display countdown restarts unexpectedly .....  | 23        |
| Scanner Internal Checks .....  | 23        |
| Scanner Check 1 - scanner communications checklist .....   | 23        |
| Scanner Check 2 - scanner power checklist .....  | 23        |
| Check List 3 .....   | 24        |
| Radar Target Image blank / faulty (missing radar targets, no radar scan, poor performance, etc.) ..... | 24        |
| External Checks .....  | 24        |
| Check List 9 .....   | 34        |
| MOD/PSU PCB .....  | 34        |
| General Information .....  | 34        |
| Magnetron Dummy Load .....   | 34        |
| Ship Supply Power Input .....  | 35        |
| Receiver Power Supply Output .....   | 35        |
| Magnetron Interface .....  | 36        |
| Ships Heading Sensor Opto-coupler Interface .....  | 36        |

|  |           |
|--|-----------|
| Ships Heading Output .....                                   | 36        |
| Stepper Motor Control .....                                  | 36        |
| Stepper Motor Interface .....                                | 37        |
| PSU Control/Status .....                                     | 37        |
| Modulator Control/Status .....                               | 38        |
| 3.6 Diagnostics Menu – detailed description .....            | 39        |
| <b>Chapter 4. Setting-up Procedures .....</b>                | <b>45</b> |
| 4.1 Fitting of Replacement IF Receiver PCB .....             | 45        |
| 4.2 Fitting of Replacement Magnetron or LNC .....            | 45        |
| 4.3 Bearing Alignment .....                                  | 45        |
| 4.4 Display Timing .....                                     | 45        |
| 4.5 Tune Preset .....  | 46        |
| <b>Chapter 5 . Replacement Parts .....</b>                   | <b>47</b> |
| 5.1 Spare Parts Lists .....                                  | 47        |
| 18" Radar Scanner Unit .....                                 | 47        |
| 24" Radar Scanner Unit .....                                 | 47        |
| Radar Core Assembly .....                                    | 48        |
| 18" and 24" Scanner (common spares) .....                    | 49        |
| 4.2 18" and 24" Scanner Units - replacement of parts .....   | 49        |
| Category A .....   | 50        |
| Category B .....   | 51        |
| <b>Chapter 6. Drawings .....</b>                             | <b>55</b> |
| List of drawings .....                                       | 55        |
| 18" (2kW) and 24" (4kW) Scanner Interconnections .....       | 56        |
| Modulator/PSU Board – Top level .....                        | 57        |
| Modulator/PSU Board – Low Voltage PSU .....                  | 58        |
| Modulator/PSU Board – High Voltage PSU .....                 | 59        |
| Modulator/PSU Board – Modulator .....                        | 60        |
| Modulator/PSU Board - 3 Phase DC brushless motor drive ..... | 61        |
| Modulator/PSU Board – Stepper Motor Drive .....              | 62        |
| Modulator/PSU Board – PCB layout (2kW, stepper motor) .....  | 63        |
| Modulator/PSU Board – PCB layout (4kW, stepper motor) .....  | 64        |
| IF Receiver – Top level .....                                | 65        |
| IF Receiver – PCB Layout .....                               | 66        |



# Chapter 1. Introduction

This Raytheon Service Manual contains information to assist with maintenance and service. It is intended to be used by qualified Raytheon service representatives.

The contents of this manual, as a whole, relate to the Raytheon 'Pathfinder' radar series and the associated chartplotter displays. The manual is divided into several **parts**. This **part** relates to the two radome scanner units:

- 2D 18" radome, 2 kW scanner unit
- 4D 24" radome, 4 kW scanner unit

Other **parts** relate to General matters and (small groups of) specific units. Refer to the Master Table of Contents at the front of the manual for brief details of each of the other **parts**. Further **parts** will be added to the manual as this family of products grows.

## Overview

**Chapter 2:** Contains the technical description of the radome scanner units and gives a general overview of the complete unit, then brief details of each PCB or main circuit.

**Chapter 3:** Part 1, Chapter 3 provides information to isolate radar problems to either a scanner or a display unit. This Chapter then gives further fault finding procedures, specifically for the radome scanner units, utilising the built-in diagnostics, flow charts and monitoring points to reduce the problem to PCB or sub-unit level.

**Chapter 4:** Contains any setting-up that may be necessary after service or fitting of a spare part.

**Chapter 5:** Contains the spare parts lists that are cross-referenced to the exploded view drawings to aid identification. These drawings are also used for dismantling and assembly. Additional notes supplement the drawings.

**Chapter 6:** Contains the scanner unit interconnection drawing, circuit diagrams and their associated layouts.





## Chapter 2. Technical Description

### 2.1 Overview

#### Scanner configuration

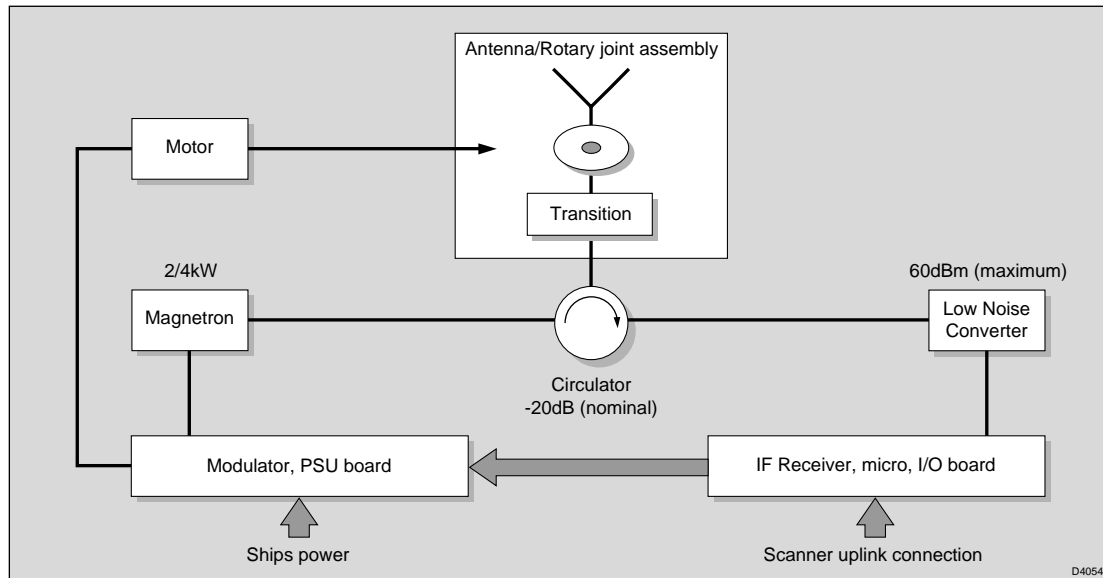

Figure 1. Scanner Block Diagram

The system comprises the functional blocks as shown in the above diagram. The basis of operation is as follows:

The **Modulator, PSU board** generates a high voltage pulse of 80nS, 250nS or 700nS duration dependant upon the range setting and the corresponding IF/video filter control lines. This pulse begins on the rising edge of a negative going trigger at a pulse repetition frequency (PRF) also defined by the range setting. The resulting pulse is output to the **magnetron** which converts the energy into an RF pulse at a frequency of 9.41GHz (nominal).

All supply requirements are also provided by the **Modulator, PSU board**.

The RF pulse is routed to an **antenna** via a 3-port **circulator** which propagates microwave energy in only one direction and thereby provides isolation between the transmit source and the **low noise converter**. A rotary joint is used to maintain continuity between a waveguide output from the circulator and a microstrip input to the antenna. This is achieved via transitions into, and back out of, a section of co-axial line which is configured with a 'split' perpendicular to the axis of rotation. The energy is then radiated by the antenna with a narrow azimuth beam shape (5.2° for the 18" patch, 3.9° for the 24" patch), with low sidelobe levels (<-22dB). The elevation beamwidth is maintained at approximately 25° in order to illuminate targets during pitch and roll of the transmitting vessel.

Echoes are returned due to reflections from potential targets such as boats, buoys, land etc, and in the form of clutter from sea, rain, etc.

The returned energy is collected by the same **antenna** used to transmit the original pulse and is routed through the **circulator** to the **low noise converter (LNC)**. These comparatively low level signals are amplified by a low noise transistor in order to maintain signal/noise performance and are mixed down to an IF frequency of 60MHz nominal for further amplification and subsequent detection.

The **IF receiver board** provides further low noise amplification and adjustable gain to maximise the dynamic range (“dynamic attenuation control”) in the presence of clutter, target and range variations.

The IF board also includes a logarithmic detection stage with approximately 50dB dynamic range, which provides a compressed signal output in terms of dB input power versus output Voltage level.

Various filtering stages are also employed in the **IF Receiver** to provide optimum signal/noise characteristics for the detected pulse and to provide some immunity against the bulk effects of rain.

The **IF Receiver** also provides the interface for the up-link commands to the scanner, including clutter and gain selection, stepper motor control and display synchronisation pulse generation.

## Receiver configuration (LNC/IF)

The basic configuration of the microwave and IF receiver circuitry is as follows :

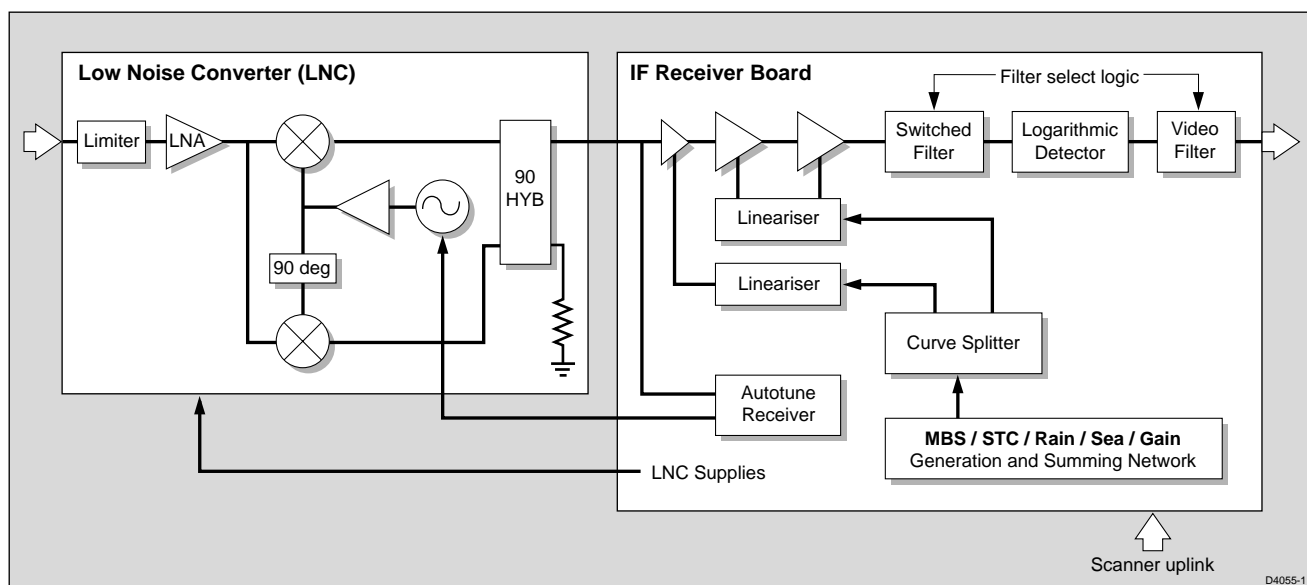

Figure 2. Receiver Configuration (LNC/IF)

## Low Noise Converter/Limiter (LNC)

The primary function of the LNC is to provide low noise amplification of the low level signal returns and mixing to an IF frequency of 60MHz nominal.

The low noise amplification is provided by a single low noise FET, with bias conditions, and associated matching set to minimise noise figure and maximise gain and compression levels. Maximum gain is required so as to minimise the noise figure contribution from subsequent stages. The mixing function is carried out in an image reject mixer configuration which reduces image noise by 20dB nominal in order to minimise the degradation in overall noise figure.

Protection is provided in the form of three limiter diodes which are configured to become forward biased in the presence of increasing RF power.

**NOTE. There are no user / dealer serviceable parts within the LNC due to its high frequency of operation.**

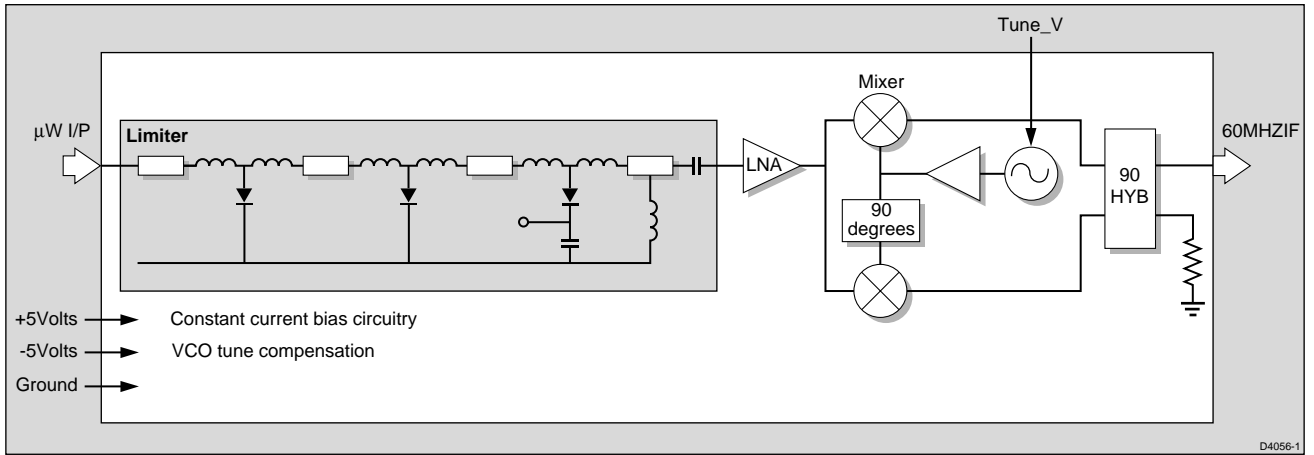

Figure 3. LNC Configuration

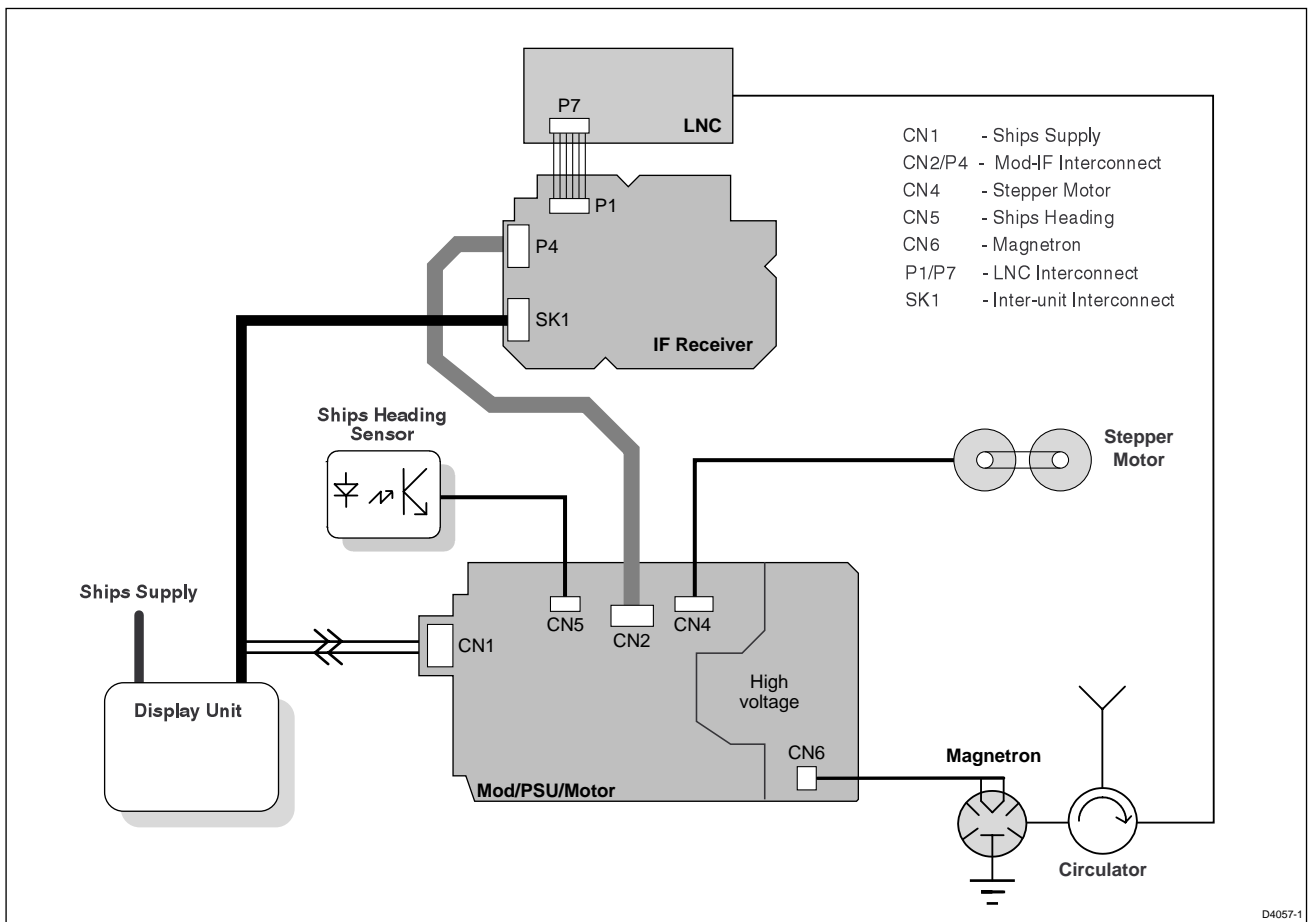

Figure 4. Scanner Interfaces

Part 2  
Chapter 2

## 2.2 Modulator / PSU – Interface Description

The interfaces to the Mod/PSU are shown in Figure 4. and the individual signal functions are described below :-

### Connectors

| Connector | Function                   | Type                             |
|-----------|----------------------------|----------------------------------|
| CN1       | Ships Supply connector     | 4 way WAGO clamp                 |
| CN2       | Mod-IF interconnect        | 18 way Picoflex ribbon connector |
| CN4       | Stepper motor connector    | 6 way Molex type                 |
| CN5       | Ships heading sensor       | 3 way Molex type                 |
| CN6       | Magnetron heater connector | 2 way Molex type                 |

### Ship Supply Power Input (CN1)

| Ref.           | Signal Name | Type        | State | Function           |
|----------------|-------------|-------------|-------|--------------------|
| CN1-5<br>CN1-6 | +BATT_IN    | Power input | –     | Ships power i/p    |
| CN1-1<br>CN1-2 | –BATT_IN    | Power input | –     | Ships power return |

### PSU Control/Status (CN2)

| Ref.   | Signal Name | Type        | State  | Function  |
|--------|-------------|-------------|--------|---|
| CN2-12 | Heater_EN_N | Logic input | 0<br>1 | Enable MOD + 6.3V, MOD + 300V, MOD +12V outputs i.e. enable magnetron heater, modulator PSU and stepper motor PSU.<br>Disable the above |

### Modulator Control/Status (CN2)

| Ref.            | Signal Name | Type                       | State                                      | Function  |
|-----------------|-------------|----------------------------|--|---|
| CN2-18          | RADAR_TX_EN | Logic input                | 1<br>0                                     | Enable modulator (magnetron) pulses<br>Disable modulator, regardless of activity on PRI_PLS   |
| CN2-9<br>CN2-11 | PW0,<br>PW1 | Logic input<br>Logic input | <i>PW0 PW1</i><br>0 0<br>1 0<br>0 1<br>1 1 | Select modulator pulse width as follows :-<br>80ns pulse<br>250ns pulse<br>700ns pulse<br>700ns pulse (not used)  |
| CN2-8           | PRI_PLS     | Logic input                | clock                                      | 10us+/-0.5us low. Rising edge triggers modulator pulse. Frequency will be varied according to pulse width; 80ns PRF = 2250Hz ; 200ns PRF=1500Hz, 700ns PRF=750Hz. See Figure 5. |
| CN2-3           | HEATER_OK   | Logic output               | 1<br>0                                     | Implies magnetron heater is connected and drawing > minimum current.<br>Magnetron heater faulty or magnetron disconnected.  |
| CN2-17          | MOD_ISENSE  | Analogue output            | 0-5.0V                                     | Indicates peak magnitude of magnetron anode current and thus indicates approximately peak R.F. power output. See Figure 7.  |
| CN2-16          | MOD_SENSE1  | Analogue output            | 0-5.0V                                     | Analogue voltage indicates build standard.  |
| CN2-13          | MOD_SENSE2  | Analogue output            | 0-5.0V                                     | Analogue voltage indicates build standard.  |

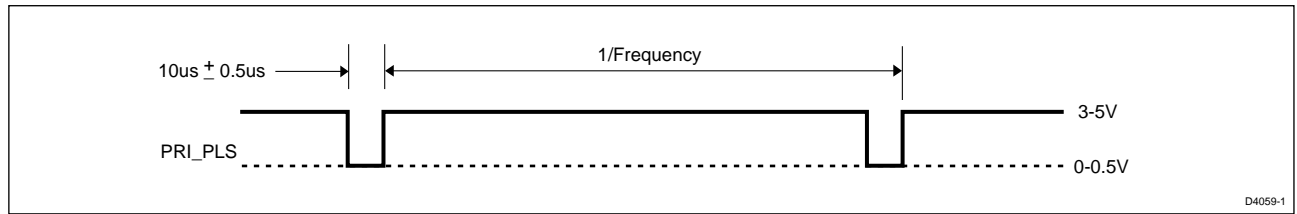

Figure 5. Modulator clock format, PRI\_PLS

## Motor Control

| Ref.   | Signal Name | Type               | State  | Function   |
|--------|-------------|--------------------|--------|--|
| CN2-12 | MOTOR_EN_N  | Logic input        | 0<br>1 | Enable Motor (either Stepper or 3-phase)<br>Disable Motor  |
| CN2-10 | STEP_IO     | Logic input/output | clock  | For stepper motor build standard: input at 181 Hz; 50% duty cycle. Determines stepper motor speed.<br>For all build standards this line acts to identify the type of build standard in conjunction with the MOTOR_EN_N control as follows:<br>When MOTOR_EN_N=1 (motor = off) :<br>STEP_IO = 1 for stepper motor build standard. |

## Ships Heading Interface

| Ref.   | Signal Name | Type         | State | Function  |
|--------|-------------|--------------|-------|---|
| CN2-15 | SHP_IN      | Logic output | clock | Neg. going edge: Indicates antenna position is at nominal zero azimuth. |

## Receiver Power Supply

| Ref.  | Signal Name | Type  | State | Function                                      |
|-------|-------------|-------|-------|---|
| CN2-1 | IF-5V       | Power | –     | -5V power rail to receiver                    |
| CN2-2 | IF+5V       | Power | –     | +5V power rail to receiver                    |
| CN2-4 | IF+26V      | Power | –     | +26V power rail to receiver                   |
| CN2-6 | IF+12V      | Power | –     | +12V power rail to receiver                   |
| CN2-5 | GND         | Power | –     | Isolated GND return from receiver power rails |
| CN2-7 | GND         |       |       |   |

## Stepper Motor Interface

| Ref.  | Signal Name | Type     | State | Function        |
|-------|-------------|----------|-------|-----------------|
| CN4-6 | STMO1       | Analogue | –     | Phase A2 switch |
| CN4-5 | STMO2       | Power    | –     | +12V/motor      |
| CN4-4 | STMO3       | Analogue | –     | Phase A1 switch |
| CN4-3 | STMO4       | Analogue | –     | Phase B1 switch |
| CN4-2 | STMO5       | Power    | –     | +12V/motor      |
| CN4-1 | STMO6       | Analogue | –     | Phase B2 switch |

## Ships Heading Sensor Opto-coupler Interface

| Ref.  | Signal Name | Type     | State | Function  |
|-------|-------------|----------|-------|---|
| CN5-1 | BZ          | Analogue | –     | Opto emitter connection                         |
| CN5-2 | +5V         | Power    | –     | +5V to Opto LED anode and collector connection  |
| CN5-3 | SHGND       | Power    | –     | Current limited Opto LED cathode GND connection |

### Magnetron Interface

| Ref.  | Signal Name | Type            | State | Function  |
|-------|-------------|-----------------|-------|---|
| CN6-1 | HEATER      | Analogue output | –     | Magnetron heater/cathode power and signal connection. |
| CN6-2 | HEAT/CATH   | Analogue output | –     | Magnetron heater/cathode power and signal connection. |

**Note:** The polarity of these two signals is immaterial. The magnetron anode connection is made through the body of the device to the local GND.

## 2.3 Modulator / PSU – Circuit Description

### Design Overview

The Modulator / PSU PCB integrates the modulator, power supply and motor drive functions of the radar scanner assembly.

The power supply section provides regulated power to all functions within the scanner unit. The modulator drives the magnetron when triggered from a simple logic input with one of three pre-set pulse widths selected by the IF receiver. The Motor Controller drives the stepper motor which rotates the antenna.

One common PCB design is used for all current Pathfinder radar systems, however the build standard is changed to suit differing configurations (motor type, magnetron power, etc).

The figure below shows an overall block diagram of the Mod/PSU PCB showing the principal circuit blocks :

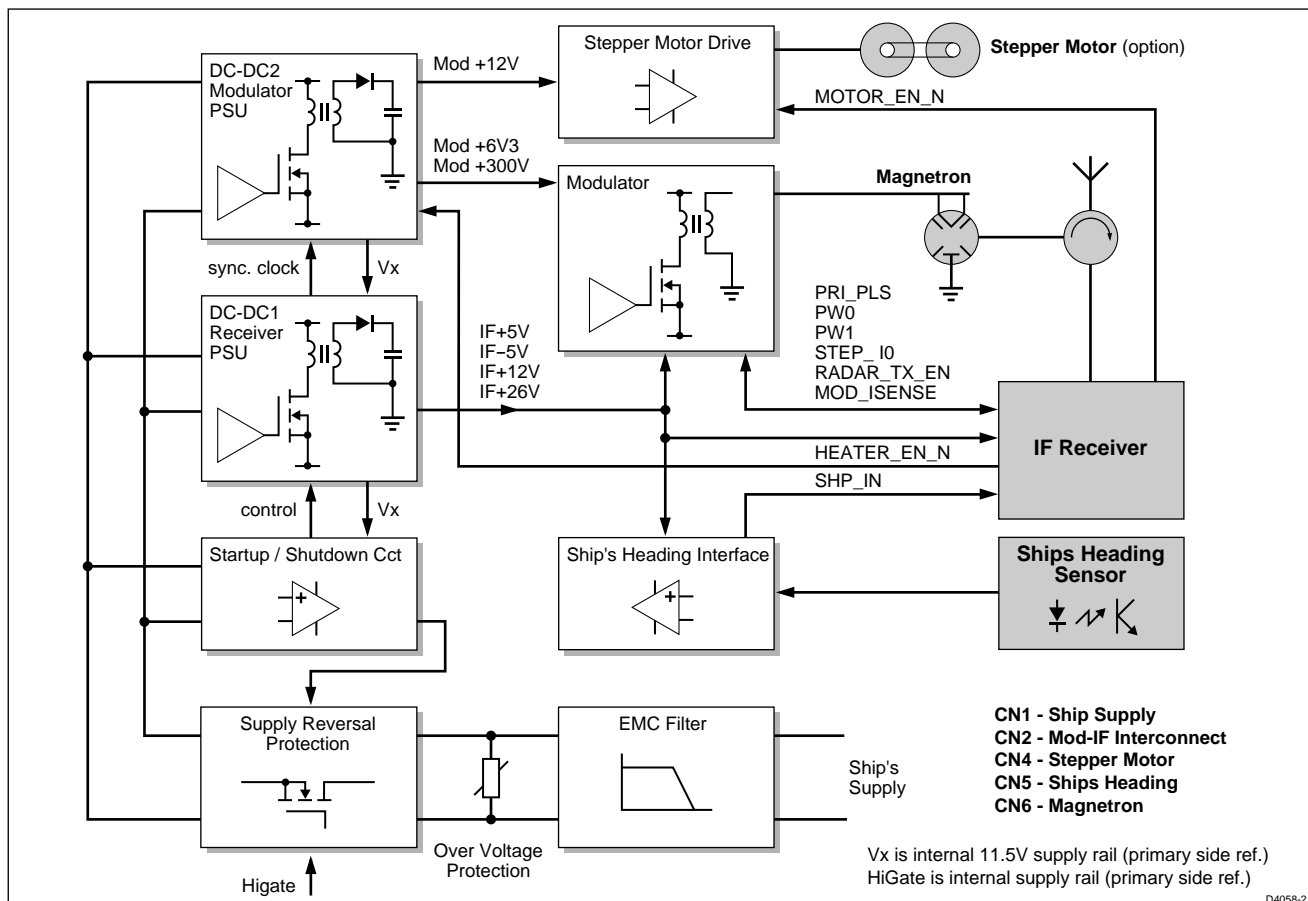

Figure 6. Modulator/PSU Overview

## Circuit Description

### *EMC Filter*

The EMC filter section comprises of a common mode inductor and associated filter capacitance's to minimise EMC problems with other electronic equipment.

### *Over Voltage Protection*

A varistor, VD1, protects the unit from over voltage surges.

### *Supply Reversal Protection*

The scanner is protected from inadvertent reversal of the ships supply by FET, Q56. This FET will not connect the ships supply to the board as long as its polarity is reversed. When the ships supply is connected correctly the FET will switch on as the internal charge pump formed by D59, D60, etc drives the HIGATE supply to approx. 12V greater than the ships supply voltage.

### *DC-DC1 and Start / Shutdown Circuit*

This is a switch mode power supply unit which derives the low voltage supplies for the receiver assembly. It is configured as a flyback converter whereby the ships supply is switched at approx. 72kHz across the primary of transformer Tx2 by FET Q38. Pulse width modulation (PWM) control is by IC U12 which senses the voltage of an internal power rail, Vx, and drives the FET to maintain voltage regulation. With the exception of the internal supply Vx which has the ships supply as its ground reference, all other output voltage rails are isolated from the ships supply and therefore must be ground referenced to the secondary side when measured (note when fitted within the core assembly the secondary side ground reference is connected to the main metal casting).

This supply is itself powered from one of its own output rails, Vx, the power back winding with initial start-up current from the ships supply. The supply is protected from operation at inadequate ships supply voltages by the start/shutdown circuit comprising of Q57, Q58, etc. This circuit will shut the supply down if the ships supply falls below the minimum scanner operating voltage of 8.7V.

This supply is configured as the 'master' supply and therefore it must be running before the high voltage supply DC-DC2 will function. Thus a fault in this unit is likely to shutdown the high voltage supply.

### ***Scanner operating supply voltage range***

| Parameter  | Units | Min. | Max.   | Conditions  |
|--|-------|------|--------|---|
| Input Voltage Range  | V     | 8.7  | 32.0   | Measured at PCB input terminals.  |
| Reverse polarity leakage current   | uA    | 0    | +/-100 | Continuous ignoring any initial transient.                                  |
| Max. Leakage current between isolated secondary GND and ships -BATT_IN (CN1-1/4) | uA    | 0    | +/-1   | Measured with 32.0V differential imposed between -BATT_IN and isolated GND. |

## Output Specification DC-DC1

| Parameter             | Units | Min. | Nom. | Max. | Conditions   |
|-----------------------|-------|------|------|------|--|
| IF-5V output voltage  | V     | -5.6 | -6.0 | -6.4 |  |
| IF-5V load            | mA    | 0    |      | 125  | Load will be reduced to minimum during standby state of IF receiver. |
| IF+5V output voltage  | V     | 4.7  | 5.0  | 5.3  |  |
| IF+-5V load           | mA    | 50   |      | 350  | Load will be reduced to minimum during standby state of IF receiver. |
| IF+12V output voltage | V     | 11.2 | 12.0 | 12.4 |  |
| IF+12V load           | mA    | 0    |      | 300  | Load will be reduced to minimum during standby state of IF receiver. |
| IF+26V output voltage | V     | 25.0 | 27.0 | 29.0 |  |
| IF+26V load           | mA    | 1    |      | 2    |  |

## DC-DC2

The operation of this switch mode power supply is very similar to DC-DC1. This supply generates the magnetron heater supply, the modulator high voltage supply (200-300V) and the 12V supply for the stepper motor. As for DC-DC1 a PWM control IC, U11, regulates the switching of a FET, Q37, which switches the ships supply across the primary of transformer Tx1. U26 and associated components, provide voltage feedback from the magnetron heater voltage rail. The high voltage modulator supply rail comprises of a number of series connected secondaries.

The PWM controller switches in synchronisation with DC-DC1 at approximately 72kHz. This supply is a slave to DC-DC1 and will shutdown with DC-DC1.

This supply is switched on by a low state on the the control signal, HEATER\_EN\_N (CN2-12). In normal operation this supply is disabled only when the radar is switched to 'standby mode'.

**Note:** This supply requires that a magnetron heater load (or a 12 ohm/4W resistor) is connected at CN6 in order to function correctly, if the supply is operated with no connection at CN6 no damage will occur but the supply voltages may be found to be out of specification. (Also see Stepper Motor Controller)

## Output Specification DC-DC2

| Parameter               | Units | Min. | Nom. | Max. | Conditions                              |
|-------------------------|-------|------|------|------|---|
| MOD+6.3V output voltage | V     | 6.0  | 6.3  | 6.6  | Measured as differential voltage at CN6 |
| MOD+6.3V load           | mA    | 430  |      | 650  |   |
| MOD+300V output voltage | V     | 196  | 210  | 224  | 2kW systems                             |
| MOD+300V load           | mA    | 0    |      | 25   | 2kW systems                             |
| MOD+300V output voltage | V     | 250  | 270  | 288  | 4kW systems                             |
| MOD+300V load           | mA    | 0    |      | 50   | 4kW systems                             |
| MOD+12V output voltage  | V     | 11.2 | 12.0 | 12.8 |   |
| MOD+12V load            | mA    | 350  |      | 500  | 2-phase, unipolar stepper motor         |



## Modulator

**IMPORTANT: The modulator circuit contains very high voltages and energy levels, care should be exercised in all maintenance activities in this area. Only those items which appear on the RME spares list may be replaced.**

The modulator's function is to drive the magnetron in order to generate a transmit pulse at approx. 9.4GHz to the antenna. The modulator is required to generate three different pulse widths as selected by external logic control lines, PW0, PW1. The modulator is fired when triggered by the rising edge of the PRI\_PLS logic level control signal from the micro controller. In addition a further control line RADAR\_TX\_EN is used to over-ride PRI\_PLS and disable transmission when held low. Output sense lines indicate correct operation to the external micro controller.

The modulator comprises a high voltage pulse transformer, Tx3 and a switching FET Q42 together with associated control and pulse shaping circuitry. In operation the control circuitry selects one of three pulse widths which then drive the FET gate via IC U22. As the FET turns on it switches the high voltage supply, +MOD\_300V, across the very low impedance of the pulse transformer primary. The current rapidly rises in the FET and its series source resistors (R132, R133, etc) until the FET begins to turn-off thus holding the current at a constant level. The resulting primary voltage pulse causes an associated secondary pulse stepped-up by the transformer turns ratio to several kV. When the secondary voltage reaches the magnetron switch-on threshold it will 'fire' generating a burst of microwave power at several kW and at a frequency of approx. 9.4GHz.

The FET is protected from operation at excess temperature by a thermistor, PT1 screwed to the FET heatsink and its associated circuitry. It is further protected from operation with unstable supply voltage by Q54.

The control circuitry comprises of a number of monostables. Each of which generates one of the three different pulse widths used for different range settings. Three variable resistors, RV1, RV2 and RV3, set the exact pulse width required. These variable resistors are preset at the factory. They require specialist equipment for tuning and must not be adjusted by the service engineer.

Two circuit blocks monitor the performance of the modulator / magnetron to provide diagnostic information for service personnel which may be read in the diagnostics menu at the display unit.

- Comparitor Q62, Q63 senses the correct flow of magnetron heater current and provides an output, HEATER\_OK which is normally a logic high when the magnetron is connected and the high voltage supply is enabled (in transmit mode or during the 70 second warm-up period).
- Peak detector D55, etc detects the peak pulsed magnetron current flow and derives the signal MOD\_ISENSE which gives some indication of the transmit power. Note that the presence of the pulse shaping circuitry alone results in some current flow and so this indicator must be interpreted with care.

| System Power | Parameter  | Units | 80ns Pulse Width |      | 250ns Pulse Width |      | 700ns Pulse Width |      | Conditions |
|--------------|------------|-------|------------------|------|-------------------|------|-------------------|------|------------|
|              |            |       | Min.             | Max. | Min.              | Max. | Min.              | Max. |            |
| 2kW          | MOD_ISENSE | V     | 1.9              | 3.0  | 2.2               | 3.0  | 2.2               | 3.0  |            |
| 4kW          | MOD_ISENSE | V     | 1.3              | 2.4  | 1.6               | 2.4  | 1.8               | 2.4  |            |

Figure 7. MOD\_ISENSE Voltage

Modulator Clock, PRI\_PLS

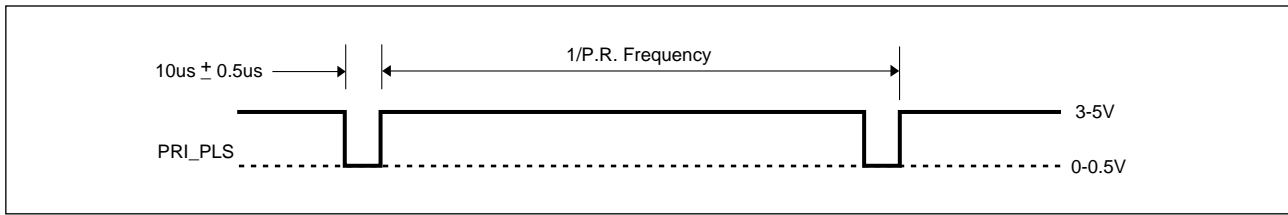

Figure 8. Modulator clock, PRI\_PLS

Ships Heading Sensor

The ships heading sensor is used to indicate that the antenna is aligned with the vessels fore and aft line. It provides one output pulse per antenna revolution. This information is utilised by the IF receiver to synchronise the radar output to the ships heading.

A slotted optical transducer is interrupted by the principal gear of the antenna rotary joint assembly. This results in a negative going pulse at CN5-1. This pulse is variable in amplitude with ambient lighting level and device tolerance. This pulse is conditioned by the interface formed by U23 and reappears as SHP\_IN at CN2-15 as a negative going pulse of approximately 5V amplitude. If the antenna is rotating normally this pulse will have a repetition rate of approximately 2.5 seconds.

Stepper Motor Controller

A stepper motor is used to rotate the antenna of all radome radar units. The stepper motor is a 2-phase unipolar type driving the antenna main gear by means of a flexible belt. The stepper motor is mounted to the main casting which provides heat sinking for the motor. The motor frequency is determined by the frequency of the external drive clock, STEP\_IO which originates at the IF board micro controller and is nominally 181Hz. The motor drive interface comprises U24 and associated circuitry. An enable signal, MOTOR\_EN\_N switches the motor drive on when at logic 0. The motor is connected at CN4. Pins 2 and 5 are the raw 12V motor supply (only active when the high voltage PSU, DC-DC2, is enabled). Pins 1,3,4 and 6 carry the motor winding drive signals. If any winding drive signal becomes disconnected the motor will normally fail to rotate but will vibrate instead. If the magnetron heater at CN6 is disconnected the motor may rotate with reduced torque.

2.4 IF Receiver PCB – Interface Description

The Interfaces to the IF Receiver are shown in Figure 4.

The individual signal functions are described below:-

Connectors

| Connector | Function   | Type  |
|-----------|--|---|
| SK1       | Display connector for serial communications video and synchronisation timing signals | 8 way Molex C-grid socket                         |
| P1        | LNC connector  | 20 way SAMTEC CLH-110-F-D-DV-P (7 pins used only) |
| P4        | Mod-IF interconnect  | 18 way Picoflex ribbon connector                  |

**Display Connector (SK1)**

| Ref.           | Signal Name               | Type  | State  | Function   |
|----------------|---------------------------|---|--|--|
| SK1-1<br>SK1-2 | AZ_SHP_OUTB<br>AZ_SHP_OUT | clock, differential pair output                 | normally high, low going clock<br>normally low, high going clock<br>0 - 5.0V | A differential output pair providing azimuth pulses to synchronise antenna position with the display (10us duration at approximately 820 Hz). The SHP (ships heading position) pulse is superimposed on the signal once per antenna revolution (30us pulse every 2.5 secs) |
| SK1-3<br>SK1-4 | SER_IOB<br>SER_IO         | digital comms, differential pair bi-directional | 2.2 V nom. DC bias<br>2.8 V nom. DC bias                                     | An RS485 Bi-directional serial communications link operating at 19.2 kBaud. It provides control of the scanner operation and monitoring functions from the Radar display.  |
| SK1-5<br>SK1-6 | PRI_OUTB<br>PRI_OUT       | clock, differential pair output                 | normally low, high going clock<br>normally high, low going clock<br>0 - 5.0V | A differential output pair providing PRI (Pulse Repetition Interval) pulses to synchronise the firing of the transmitter with the display video. Rate is according to range setting.   |
| SK1-7<br>SK1-8 | VIDEO GND<br>VIDEO        | Analogue Video output                           | AC coupled 1.75V max peak signal into 75 ohms                                | The raw Radar video signal from the scanner.   |

Part 2  
Chapter 2

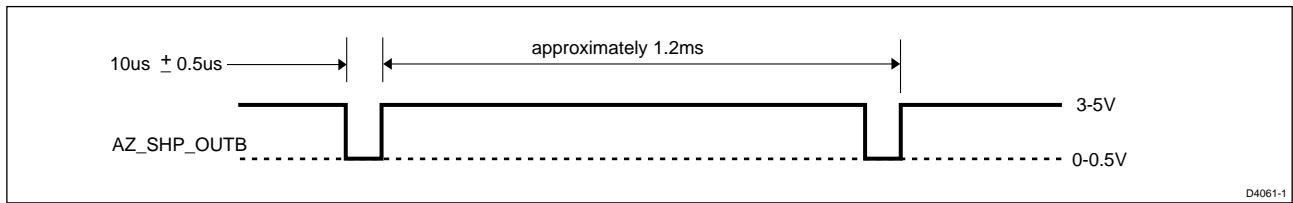

Figure 9. AZ\_SHP\_OUTB / AZIM\_DNEG

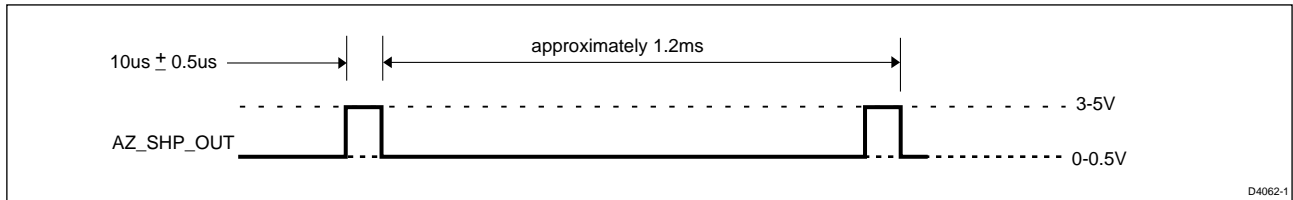

Figure 10. AZ\_SHP\_OUT / AZIM\_DPOS

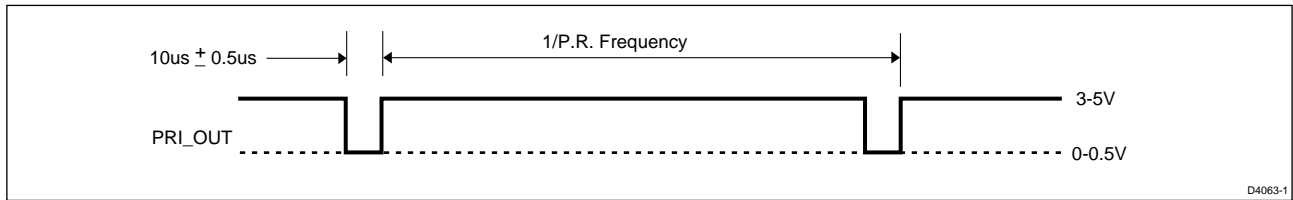

Figure 11. PRI\_OUT / PRI\_DPOS

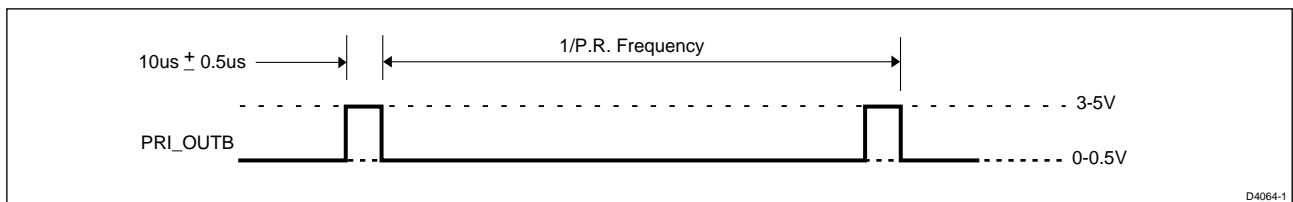

Figure 12. PRI\_OUTB / PRI\_DNEG

**LNC Connector (P1)**

| Ref.         | Signal Name     | Type   | State                                      | Function  |
|--------------|-----------------|--|--|---|
| P1-1<br>P1-2 | GND<br>60MHz IF | 60MHz Intermediate Frequency (IF)<br>Radar received signal input | N/A  | The down-converted received radar signal from the LNC at 60MHz carrier frequency.   |
| P1-3         | Not Connected   | N/A  | N/A  | N/A   |
| P1-4         | RF_ATTENV       | Analogue control voltage output                                  | 0 - 10V                                    | A control voltage to apply RF attenuation to the LNC limiter diodes. This function is not used by SL72 and SL74 systems.          |
| P1-5         | TUNE_V          | Analogue control voltage output                                  | 4 - 24V                                    | A control voltage that is applied to the LNC VCO (Voltage Controlled Oscillator) to maintain the tuning of the IF input to 60MHz. |
| P1-6         | GND             | Analogue output  | 0V   | Analogue ground reference for the LNC supplies.   |
| P1-7         | +5V             | Analogue Output (switchable)                                     | 0V in standby mode<br>+5V in transmit mode | The 5v supply for the LNC. It is switched off in standby mode to save power.  |
| P1-8         | -5V             | Analogue Output  | -5.9V nom.                                 | The -5.9V supply for the LNC  |

Part 2  
Chapter 2

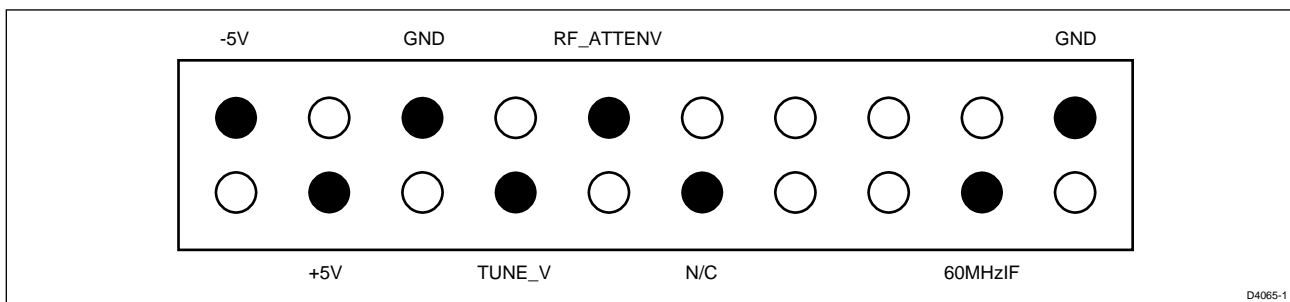

Figure 13. LNC Connector P1 connections as viewed from component side of board

**Mod / IF Interconnect (P4)**

This connector P4 is pin to pin identical to CN2 connector on the MOD / PSU PCB. See MOD / PSU interface section for details.

**2.5 IF Receiver – Circuit Description**

*Main Receiver*

The prime function of the IF receiver is to provide low noise amplification and logarithmic detection of the 60MHz IF (Intermediate Frequency) Radar received signal, to give a video signal output suitable for displaying on the Radar screen (after digital processing at the display).

The receiver provides low noise amplification, dynamic IF gain control (STC) and selectable IF bandwidths to optimise target detection for all ranges and for various sea and weather conditions. The following summarises the functions of the circuitry.

A low noise amplifier (AR1), is situated prior to an adjustable gain monolithic microwave integrated circuit (MMIC) amplifier stage (U9 and U10) in order to define the noise figure of the system. This incorporates the relevant circuitry to provide fast gain control via the STC generator.

General amplification and attenuation control is also provided by the cascaded MMIC amplifiers U9 and U10 in conjunction with factory-tuned inductors (L4, L10 and L11) and capacitors to tailor the bandwidth characteristics of the circuit.

IF Bandwidth switching between 12MHz and 3MHz is configured to provide matched filtering for the shorter 80ns and 250ns pulses respectively which is automatically set when the Radar range is adjusted. Gain is increased accordingly to maintain a relatively constant noise power at the receiver output.

A switched video filter is used in conjunction with the 3MHz IF filter to provide matched filtering for the longest 700nS pulse. This is typically 0.69MHz wide

Remaining variations in noise power as a consequence of the different signal bandwidths (i.e. noise power is directly proportional to bandwidth) are adjusted in the display.

A 'fast time constant' circuit is used to provide a continuously variable high pass filter to provide some immunity against the bulk effects of rain.

**N.B. The variable inductor coils L4, L10 and L11 are preset at the factory. They require specialist equipment for tuning and must not be adjusted by the service engineer.**

The PRI rates and video noise can be observed at the appropriate connectors (see interface section) for the different range settings as follows:

### ***Summary of bandwidths, pulse widths and PRI rates***

| <b>Radar Range Setting</b> | <b>IF BW</b> | <b>Video BW</b> | <b>Pulse width used</b> | <b>PRI rate</b> | <b>Video Noise level</b> |
|----------------------------|--------------|-----------------|-------------------------|-----------------|--------------------------|
| 0.125 to 0.75 nm           | 12MHz        | 12MHz           | 80ns                    | 2250 Hz         | >500mV pk-pk             |
| 1.5 and 3nm                | 3MHz         | 12MHz           | 250ns                   | 1500 Hz         | >500mV pk-pk             |
| 6nm to max range           | 3MHz         | 0.69MHz         | 700ns                   | 750 Hz          | >250mV pk-pk             |

### *Autotune Receiver*

The autotune receiver provides frequency selective peak detection of high level 'main-bang' transmitter pulses. This is achieved using a high impedance branch from the main receiver input with a transistor/diode based amplifier/detector circuit (Q31, Q32, D16, Q33, Q37). The detection frequency bandwidth of the autotune receiver is set at the factory using variable inductors L7, L8 and L9. The output of the receiver is buffered (U6A) and passed to the scanner microprocessor. A tuning algorithm is then performed at the display to set the difference frequency between the magnetron and VCO (Voltage Controlled Oscillator) to a fixed IF frequency of 60MHz using the TUNE\_V control line P1 pin5. Both coarse and fine adjustment are provided by the microprocessor to allow for initial setting and subsequent fine tuning.

**N.B. The variable inductor coils L7, L8 and L9 are preset at the factory. They require specialist equipment for tuning and must not be adjusted by the service engineer.**

### *STC/Main Bang Suppression (MBS)*

The STC circuitry consists of a logarithmic function generator split into four outputs and multiplied by 4, 3.2 and 2 to generate the respective R4, sea clutter and rain curves respectively.

These curves are offset as requested via processor/operator demands and then combined to provide an output equal to the greatest of the inputs. A curve splitter and linearisation circuits are used to match the output control levels to the characteristics of each attenuator.

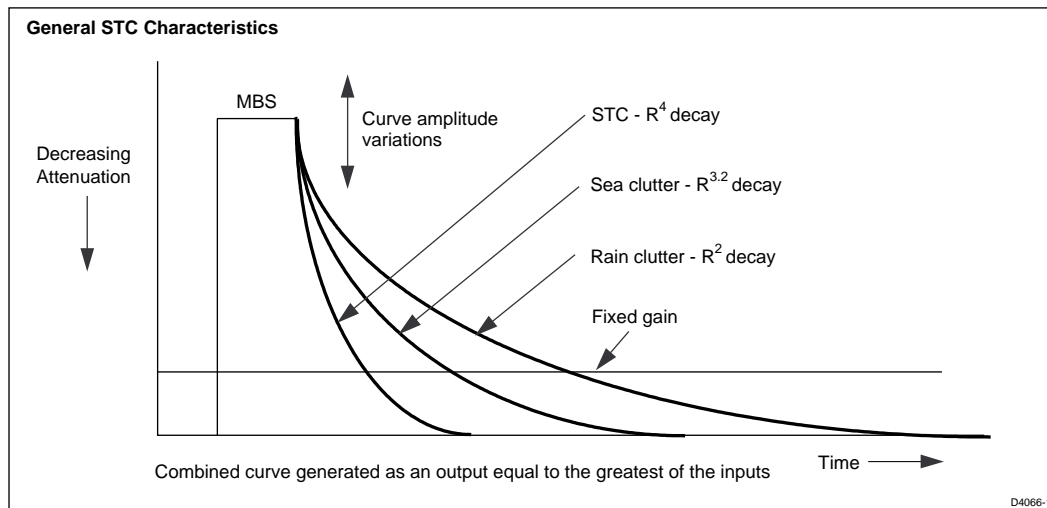

Figure 14. General STC Characteristics

Main bang suppression amplitude and duration controls are configured so as to override these STC controls.

For low values of attenuation the attenuation is applied to the Monolithic amplifiers in order to preserve system noise figure. At higher values of attenuation the attenuation is divided between the IF pin attenuator (D17) used to control the first IF amplifier stage, and the Monolithic amplifiers.

### Microcontroller

The microcontroller subsystem, using an NEC 78054 device, is integrated onto the IF receiver board and provides the following functions :-

- Generates analogue control voltages via a multi channel Digital to Analogue Connector (DAC) for all user and automated scanner adjustments
- Reads the tune indicator input and adjusts tune control voltage as necessary.
- Controls modulator pulse width selection.
- Generates stepper motor pulses
- Generates Azimuth pulses for display synchronisation.
- Generates the PRI (Pulse Repetition Interval) pulses to fire the magnetron, start the STC cycle and synchronise the display.
- Buffers the Ships Heading Pulse from the MOD/PSU PCB for synchronising the display.
- Communicates with the display via a serial interface.

### Initial Scanner set up (EEProm stored values)

The scanner has non volatile storage (EEProm U18) for the following items:-

- Optimum VCO coarse and fine tune settings for Short, Medium and Long pulses
- MBS Duration and Amplitude for Short, Medium and Long pulses
- Range Zero Offset (adjusted by Display Timing function in Advanced settings Menu) for Short, Medium and Long pulses
- Stepper motor ramp time and pulse period - pre-set at factory - non adjustable
- Azimuth zero offset (adjusted by Bearing Alignment function in Radar Set Up Menu)

- PRI Jitter Offset - used to help with interference rejection.
- STC Preset Max - a preset level of R<sup>4</sup> clutter curve is set to equalise close target returns
- Scanner Size - storage of the antenna size fitted to the Scanner - used to set Max Range for Display
- Modulator Power - The power of the modulator in kW - also used to set Max range for Display

The above stored parameters each have a factory set and used working location. These values are set at the factory and are optimised for each individual scanner unit to provide optimum performance and a good starting value when the Radar system is first operated. However, the VCO tuning, range zero offset and Azimuth zero offset used working values are adjustable from the display during Radar operation.

Due to temperature variations affecting the LNC, the VCO tuning values are adjusted by the display when Auto mode is selected to give optimum tuning. The present optimum value is stored when a range change (i.e. transmit pulse length change) is made, so that when the range is selected again, the auto-tune function is at a better starting point. Normally this adjustment is made just to the fine tune value for each pulse length. Occasionally, a change in coarse tune may be necessary. If tuning problems occur, the Tune Preset function in the Advanced Settings Menu provides a manual way of adjusting the coarse tune used working value.

The Range Zero Offset is adjusted manually from the display Advanced Settings Menu (Display Timing) as part of the normal Radar installation procedure. If the inter unit cable is kept to the supplied length the Display Timing should not normally need adjusting.

STC preset maximum is set at the factory, however the STC preset value can also be changed via the Advanced Settings Menu.

When a Factory Reset is performed (press MENU, select SYSTEM SET UP, the press and hold MENU for 5 second countdown) the scanner copies the Factory set values back into the used working locations of the EEprom so the scanner and display are as they were set up when they left the factory.

The EEprom also stores the scanner Build Standard information that is accessible through the Diagnostics Menu - see chapter 4 - fault finding.

## 2.6 Antenna / Rotary Joint Assembly

The scanners use either 18" or 24" microstrip patch arrays

The primary specifications for the antenna / rotary joint assembly are as follows :-

| Parameter                      | 18" Radome         | 24" Radome         |
|--------------------------------|--------------------|--------------------|
| Operating frequency            | 9.410GHz ± 63MHz * | 9.410GHz ± 63MHz * |
| Azimuth beam angle             | 5.2° nom           | 3.9° nom           |
| Elevation beam angle           | <28° nom           | <28° nom           |
| Antennae gain across bandwidth | 22.3dB nom         | 22.9dB nom         |
| Return loss                    | >15.0dB            | >15.0dB            |
| Sidelobe levels                | >22.0dBc           | >22.0dBc           |

\* Bandwidth requirements are defined by the magnetron uncertainty

Figure 15. Antenna Outline Performance

## 2.7 Scanner Display Connection

The scanner / display interface is a universal link between any display and any scanner. It consists of a single, multi-core cable with a single moulded plug at the display and multiple connections at the scanner:

- Video, Serial bus, PRI, Azimuth/Ships heading pulse
- Power.

A moulded plug at the display provides the necessary sealing against the environment, whereas at the scanner this is provided with a compression cable gland, push-fit connector for signal (8 way) and sprung loaded connectors for power (2/4way).

The cable consists of the following cores :

1. 75 ohm coaxial cable carrying the 1.75V peak to peak video signal from the scanner (pins 7and8).
2. Twisted pair cable carrying the 5V differential azimuth and ships heading reset synchronising signal from the scanner (pins 1and2).
3. Twisted pair cable carrying 5V differential PRI pulse synchronising signal from the scanner (pins 5and6).
4. Twisted pair cable carrying 5V differential, bi-directional serial communications signal (RS485) between scanner and display (pins 3and4).
5. 8.7V-32V DC at scanner

With a standard 1.5 metre power cable, the maximum cable length between scanner and display is 35 metres. Combinations of inter-unit cables and their effect on power cable extensions (if any) are discussed in Section 6.5, Inter-Unit Cable and Power Cable, in the HSB Series Pathfinder Radar Owner's Handbook.



## Chapter 3. Fault Finding

This chapter details the fault finding and repair issues for the Radome Scanner Units.

Please read the 3.1 Safety Notices and 3.2 General Notes below before commencing a service operation. You should also read the 3.3 Built-in Testing/Diagnostics section as this will be of use in many cases. Begin the fault finding procedure by referring to the System Trouble-shooting Check List in **Part 1, Section 3.5** which will advise on the appropriate course of action.

### 3.1 Safety Notices

The following checks are intended only for qualified service technicians.



**DANGER**  
High voltage

When the display unit is powered with the case opened GREAT CARE MUST BE TAKEN as the unit contains DANGEROUS HIGH VOLTAGES in the circuitry and connections to the Cold Cathode Fluorescent Lamp (CCFL). Voltages in excess of 700 Volts may be present on connector SK9 and its associated cable.

The radar scanner also contains DANGEROUS HIGH VOLTAGES in the vicinity of the high voltage power supply unit, Modulator and magnetron connections.



**DANGER**  
Non-ionising Radiation

The radar scanner emits non-ionising radiation from the magnetron, circulator and antenna assemblies. There are also low levels of ionising radiation (x-rays) in close proximity to the magnetron when it is transmitting. It should not be operated in transmit mode near to any persons, or within enclosed buildings.

### 3.2 General Notes

- IMPORTANT. Whenever the microwave core assembly is removed from the radome assembly the 4 foot seals must always be renewed to guarantee the water seal integrity of the radome unit.**
- See Replacement of Parts notes and exploded views in Chapter 5 of Parts 2 and 3 for guidance in dismantling of the radar.
- The Connector / pin labelling convention used in this manual is as follows :  
J4-6 means 'connector J4, pin 6'.
- When measurements to Picoflex ribbon cable connectors are specified, these can usually be made by carefully probing the slots in the cable connector. Pin 1 is marked by the red cable stripe.
- Video Noise tests.* A number of diagnostic procedures make reference to whether video noise can be observed. The procedure for verifying this is as follows: With the Sea Clutter and Gain set to manual, as the Gain is gradually increased the screen should show increasing 'speckle' corresponding to increased video noise, indicating that the IF receiver is driving the video signal. Under normal circumstances the range of adjustment over which the screen goes from white to black is around 10% of Gain adjustment. If the video signal is not present this will occur over 1 or 2 % of Gain adjustment.
- Normal Motor Operation.* When the radar is switched on the motor commences rotation. The motor starts at a reduced speed for a few seconds and then accelerates to full speed (24 r.p.m.). The motor runs for the full warm-up countdown period, and for approximately 1 minute afterwards with the unit in standby. This is done to allow the microprocessor on the IF receiver to

measure the rotation speed of the antenna and then set the correct rate of Azimuth pulses for synchronising the display. This also allows the display sweep to be in sync immediately if transmit mode is entered within the 1 minute period. To save power the motor is stopped after the 1 minute period if the unit is left in stand-by mode. In this case the motor will re-start in the same ramped speed fashion when transmit is entered, causing a few seconds delay before the display sweep is in sync with the antenna rotation.

7. The Display unit may be powered with the case folded open after the rear case screws have been removed. If necessary the CPU PCB may be operated unscrewed from the moulding if great care is taken to ensure it does not short-circuit to any other pcb. **Under no circumstances** should the unit be operated without the LCD module plugged in to the CPU assembly (connector J8) - to do so can damage the CPU PCB assembly.
8. Both the scanner and display unit operate from an internally isolated PSU. Thus ships battery voltage measurements must be made with reference to the ships battery negative, whereas the internally derived PSU outputs must be made with reference to the secondary ground. For the display unit this can conveniently be probed at the 'GND' test pad near J7 on the CPU PCB. For the scanner unit this can be conveniently probed from the metal casting of the scanner assembly which is connected to the secondary GND. Unless otherwise stated measurements given in the text are relative to the secondary grounds.
9. When switching the display unit on/off repeatedly you will notice that it is necessary to wait for several seconds after switching off before the unit can be switched on again from the POWER key. This is quite normal.

### 3.3 Built-in Testing / Diagnostics

The Pathfinder series Radars and Chartplotters incorporate a diagnostics menu to aid the service engineer in finding some of the possible faults that could occur with the system.

The diagnostics menu can be accessed from either standby or transmit modes by the following key sequence:

Press the MENU key. Press the RADAR SET UP or CHART SET UP soft key. Press and hold ENTER for approximately 5 seconds - a new set of soft key options will appear at the bottom of the screen. Select BUILT-IN TEST.

**Note:**

Although all display variants can access the diagnostic menu, a repeater display or a RC520 will only give very limited data.

See **Diagnostics Menu - detailed description** at the end of this chapter (section 3.6) for a full description of its features.

### 3.4 Master and Repeater LCD Displays

When two displays are connected via the HSB bus, it is necessary, prior to isolating the fault to the scanner or the display, to determine which display is the master i.e. connected to the scanner. In the event that the rear of the units are not easily accessible, then this may be determined by powering both displays on and waiting for the WARMING UP banner to count down to zero.

Power one of the two units off.

A message HSB LOST will be displayed and the alarm will sound on the other unit for about 5 seconds. If this unit then shows the message STANDBY it is the Master display.

It will be possible to use scanner from the master display.

If the unit remaining powered up is the repeater, again a message HSB LOST will be displayed, and the alarm will sound for about 5 seconds. If the unit then displays SCANNER NOT RESPONDING then it is either a slave or the scanner is faulty. Repeat the procedure above on the other unit to determine if the fault is in the repeater or the scanner.

## 3.5 Check Lists

### Check List 2

SCANNER NOT RESPONDING message displayed or Start-up count-down restarts unexpectedly

#### External Checks

1. Check the inter-unit scanner cable is correctly fitted and pushed home at the rear of the display unit.

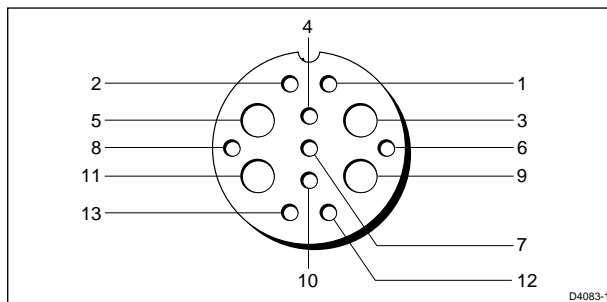

Figure 15. Scanner cable end connector

| No. | Function   | Colour        |
|-----|--|---------------|
| 1   | I/F Video information from scanner               | Coaxial inner |
| 2   | I/F Video ground                                 | Coaxial outer |
| 3   | Battery negative (filtered) to scanner           | Black         |
| 4   | Transmit trigger pulses from scanner             | Orange        |
| 5   | Battery negative (filtered) to scanner           | Black         |
| 6   | Command/data link to/from scanner                | Green         |
| 7   | Transmit trigger pulses                          | Yellow        |
| 8   | Screen   | No insulation |
| 9   | Battery positive (filtered, switched) to scanner | Red           |
| 10  | Command/data link to/from scanner                | Blue          |
| 11  | Battery positive (filtered, switched) to scanner | Red           |
| 12  | Azimuth and ship's heading pulses from scanner   | Violet        |
| 13  | Azimuth and ship's heading pulses from scanner   | Grey          |

2. Check the scanner cable for signs of damage / corrosion.
3. Check the unit is correctly supplied with power :-  
Voltage at power cable socket is between 10.7 and 32Volts (pins 5 and 3). If not check the integrity of the power cabling to the radar system.

4. With scanner cable removed measure the supply voltage on display cable plug at the rear of the display unit and check it reads between 10.7 and 32 Volts (power pins may be identified by their larger diameter compared to the signal pins). If not see **Display Check 1** on following page.
5. Now check scanner communications link. With scanner cable disconnected from rear of display measure resistance between pins 6 and 10 of scanner cable plug. A reading of approximately 160 W should be obtained. If not see **Scanner Check 1** on following page.
6. Now check display communications link.  
With scanner and power cables disconnected from rear of display measure resistance between pins 6 and 10 of the scanner cable plug at the rear of the display. A reading of approximately 160 W should be obtained. If not see **Display Check 2** on following page.
7. Turn the display unit on with the scanner disconnected. Wait until the “scanner not responding” message appears then enter the Diagnostics menu. Check the Display Comms test result. A pass indicates the display is probably OK and the fault lies in the scanner power supply or communications link.
8. Reconnect the scanner cable. Remove the radome cover. Switch the unit on but ENSURE THE UNIT IS NOT IN TRANSMIT MODE. Check that the voltage at CN-1, the power cable connector, is greater than 8.7 Volts. If it is then see **Scanner Check 2** checklist, or if the display countdown restarts unexpectedly then see **Display Check 3**. If less than 8.7 V is measured then the fault could be excessive voltage drop in the inter-unit scanner cable due to damage or corrosion. Repair or replace cable if necessary.
9. An excessive voltage drop could also be due to the scanner drawing excess current. If there is just a simple communications fault, all the scanner functions will be off and it will consume approximately 2.3 Watts. e.g. at 8.7 V it would draw 0.27Amps. Use an ammeter to measure the current drawn at CN1, and hence calculate the power. If the power is OK then proceed with **Scanner Check 1**. If the power consumption is excessive then proceed with **Scanner Check 2**.

### Display Circuit Operation

The ships supply connects on the PSU board via solder buckets to the rear panel connector. Power is applied to the units PSU when the internal relay closes. The relay is driven by either the power key via circuitry on the CPU board, or by the micro itself. Thus initial switch on occurs when the power key is depressed, causing the relay to close. The software then runs and holds the relay closed. At switch-off the software shuts the unit down, then opens the relay.

### Display Internal Checks



For all the following internal checks, with the display unit opened out and with all connectors still in place, attach a ships power cable to the rear panel connector and switch the supply on.

### Display Check 1 - Display has no power at scanner plug at rear of display

1. Check that the power reaches the Power / NMEA connector solder buckets on the PSU board. If not then there is a failure of the power / NMEA connector. The solder buckets of this connector may be probed with the CPU board in place. The connector is visible between CPU connectors J8 and J4 on the PSU board. The battery power pins are those with the thick pcb tracks running to them. If an incorrect voltage is measured then disassemble the rear cover assembly and check the rear panel connector for signs of corrosion / damage.

**Display Check 2 - Display communications check**

1. Check resistance at CPU board connector J4 between J4-11 and J4-12 is approx. 160  $\omega$  . If so must be cable fault either on rear panel bucket connector on PSU board or ribbon cable to CPU J4. Check for damage or corrosion and replace as necessary.

**Display Check 3 - Display countdown restarts unexpectedly**

1. Check that the Power cable between the PSU board PL7 and the CPU board J7 is connected, with no breaks in any cores.
2. Power the display and press the Power key. With a ground reference on J7- 2, PGND, of the cable check that the voltages shown in Checklist 10 for **CPU Power - J7** are present. If all are correct then proceed to next test, else there is a failure of the PSU PCB.

**Scanner Internal Checks**

Switch the system off at the boat's distribution panel and disconnect the scanner cables to allow the scanner unit to be removed to a dry place where it can be worked upon. Remove the radome cover and microwave core assembly.

**Note:** The 4 foot seals must always be renewed to guarantee the water seal integrity of the radome unit.

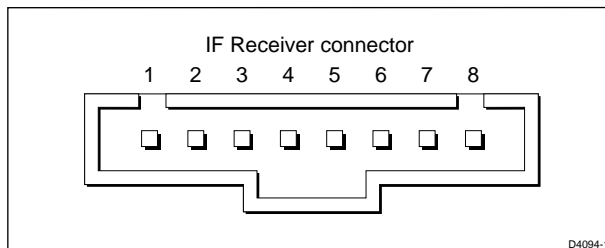

Figure 16. IF Receiver connector SK1

**Scanner Check 1 - Scanner communications checklist**

1. Check connections at scanner 8-way connector with the radome cover removed. Particularly check pin 3 (blue) and pin 4 (green) for damage or corrosion. If faulty repair or replace 8-way Molex connector (p/n R126).
2. Measure resistance between 8-way Molex connector, SK1-3 and SK1-4 and check for approximately 160  $\omega$  . If resistance measurement wrong then replace IF PCB assembly. If correct then fault must lie within the inter-unit scanner cable, replace.

**Scanner Check 2 - Scanner power checklist**

1. Check the internal receiver power supplies on the Mod/PSU. See **Receiver Power Supply Output** table in **Mod/PSU PCB Checklist 9**. If OK proceed to next test.
2. Check power to IF PCB. Remove IF metal cover plate. Check if +5 V is present at P4-2. If it is present the IF receiver is assumed to have a faulty communications circuit and should be replaced. Otherwise if +5V was not measured then check / replace the ribbon cable assembly connected to P4.

## Check List 3

Radar Target Image blank / faulty (missing radar targets, no radar scan, poor performance, etc.)

### External Checks

1. **Check that the Radome lid is fitted.** If the Radome is run in bright daylight with the lid removed, the ship's heading, Opto PCB may generate additional pulses, causing the radar sweep to reset.
2. It may be desirable to carry out a full Reset of the Radar system before continuing with the checks, indeed this may cure the fault. Note however that this will also reset Bearing Alignment, Display Timing, Tune and STC Preset to their factory defaults, and therefore these may need to be set up again as for a new installation.

To perform a system reset:

- Power-up the radar system and allow the 70 second countdown period to complete.
  - Press MENU and select SYSTEM SET-UP.
  - Press and hold the MENU key until the Reset countdown has reached zero. Release the key, the radar system will reset and restart the 70 second countdown.
  - The scanner has now been reset to factory settings.
  - Check if the fault symptoms have disappeared.
3. Check that the coarse tune setting of the Radar is correct, by adjusting the Tune Preset value in the Advanced Settings Menu. If still no targets appear or Radar image is poor then continue with this checklist, but firstly restore the Tune Preset to its previous value using the softkey "RESTORE PREVIOUS".
  4. If the fault persists see the **Diagnostics Menu flowchart A**
  5. If the unit is still faulty see **Radar image fault flowchart E**

SYSTEM FAULT FINDING DIAGNOSTIC MENU

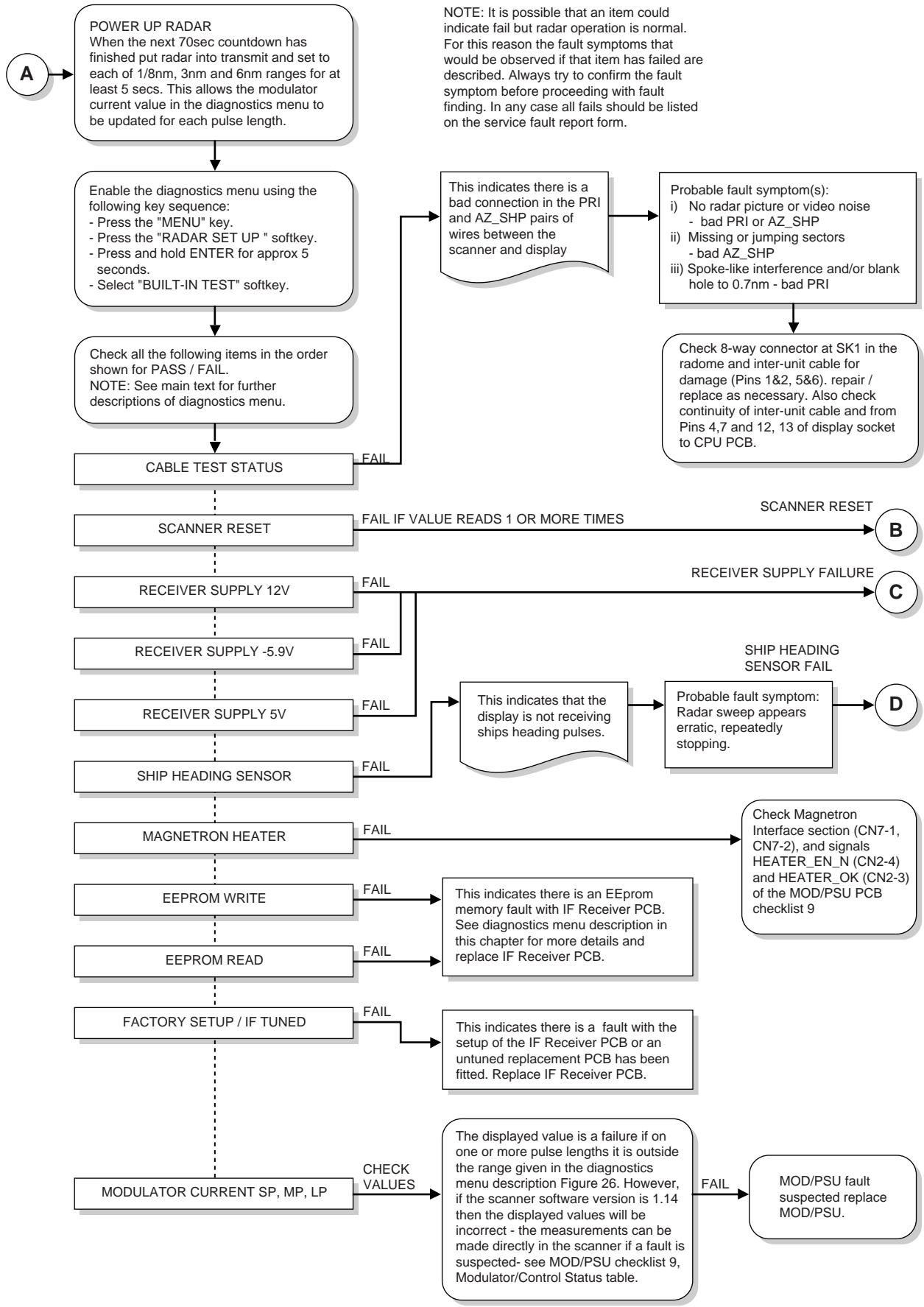

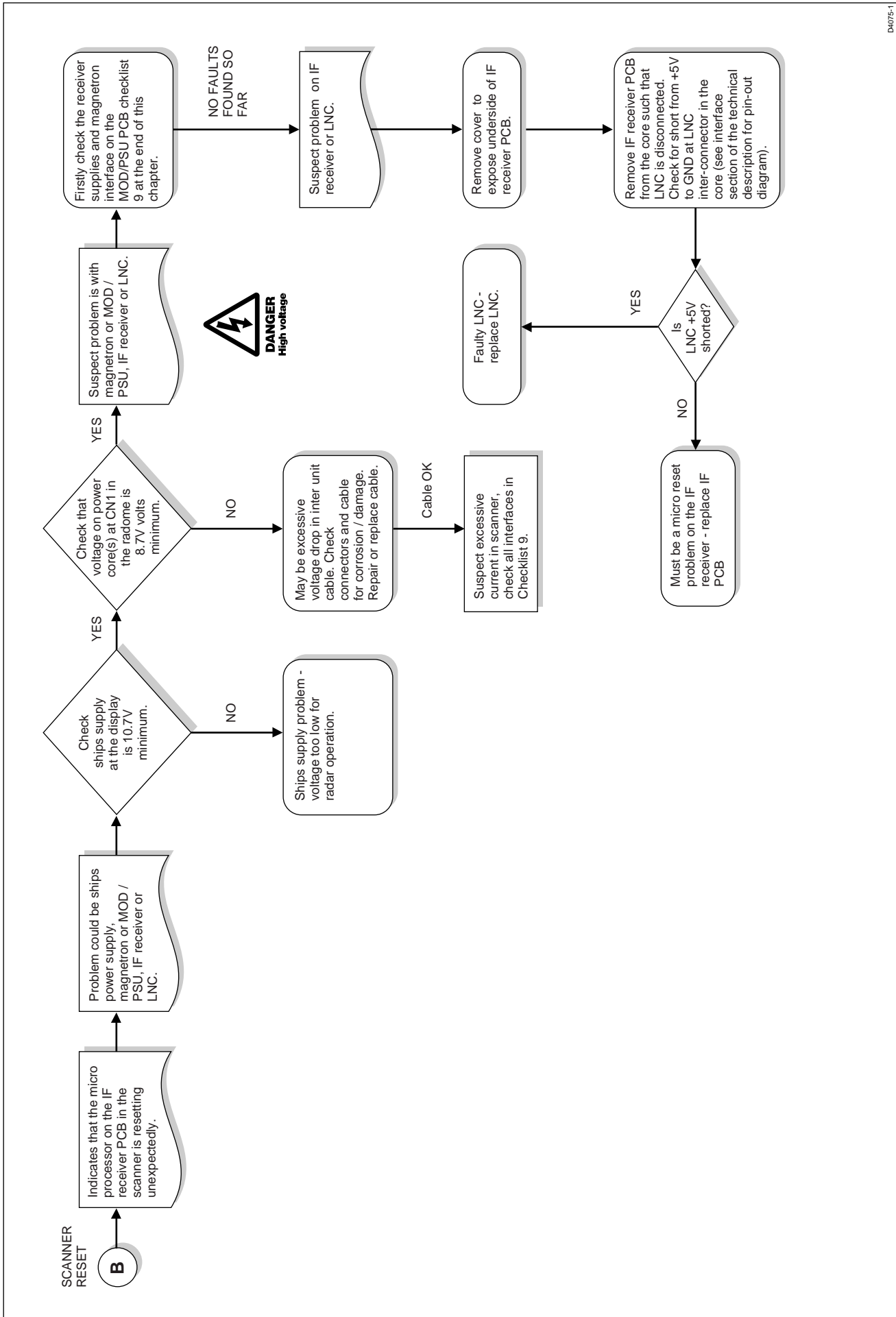

D4075-1



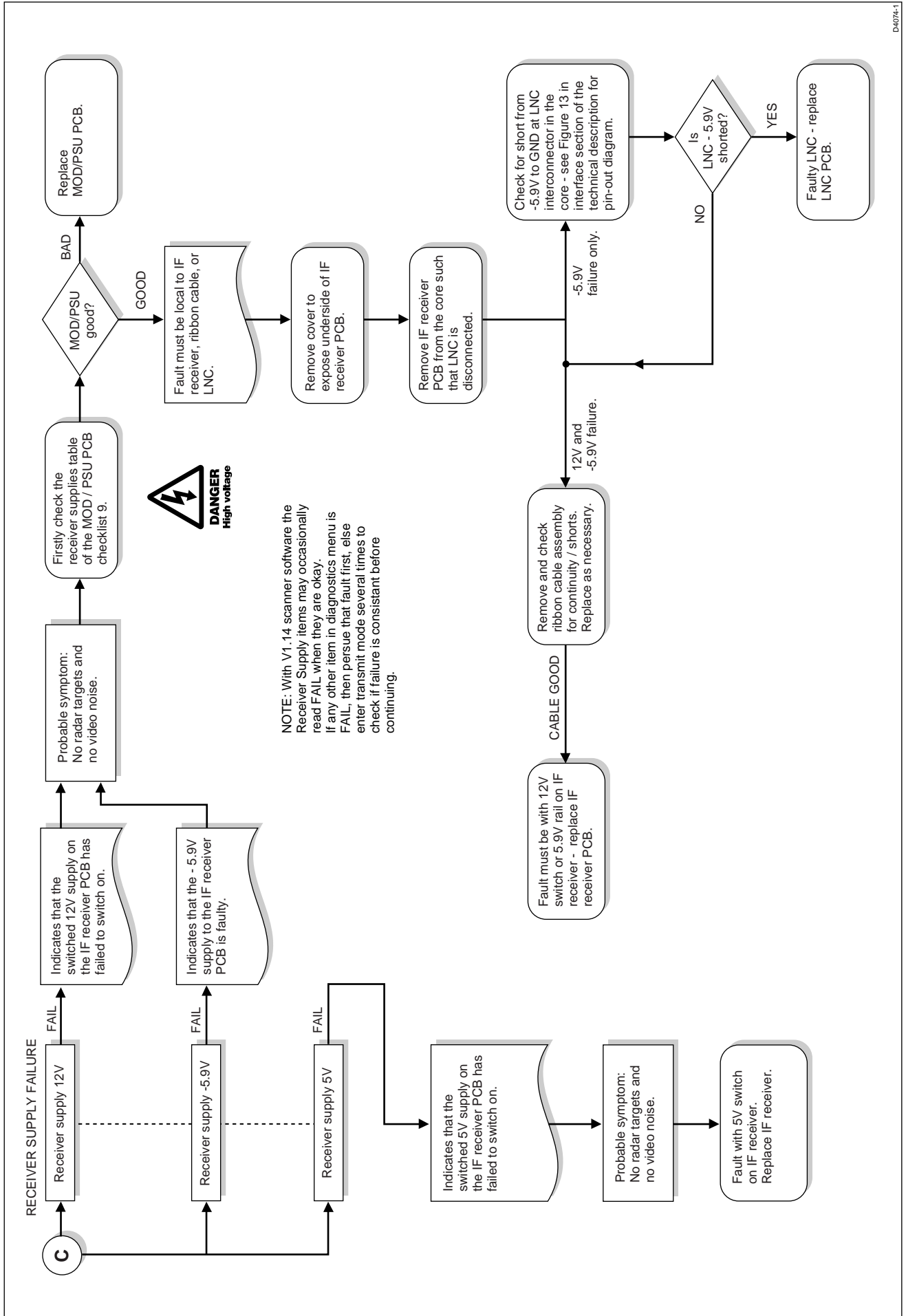

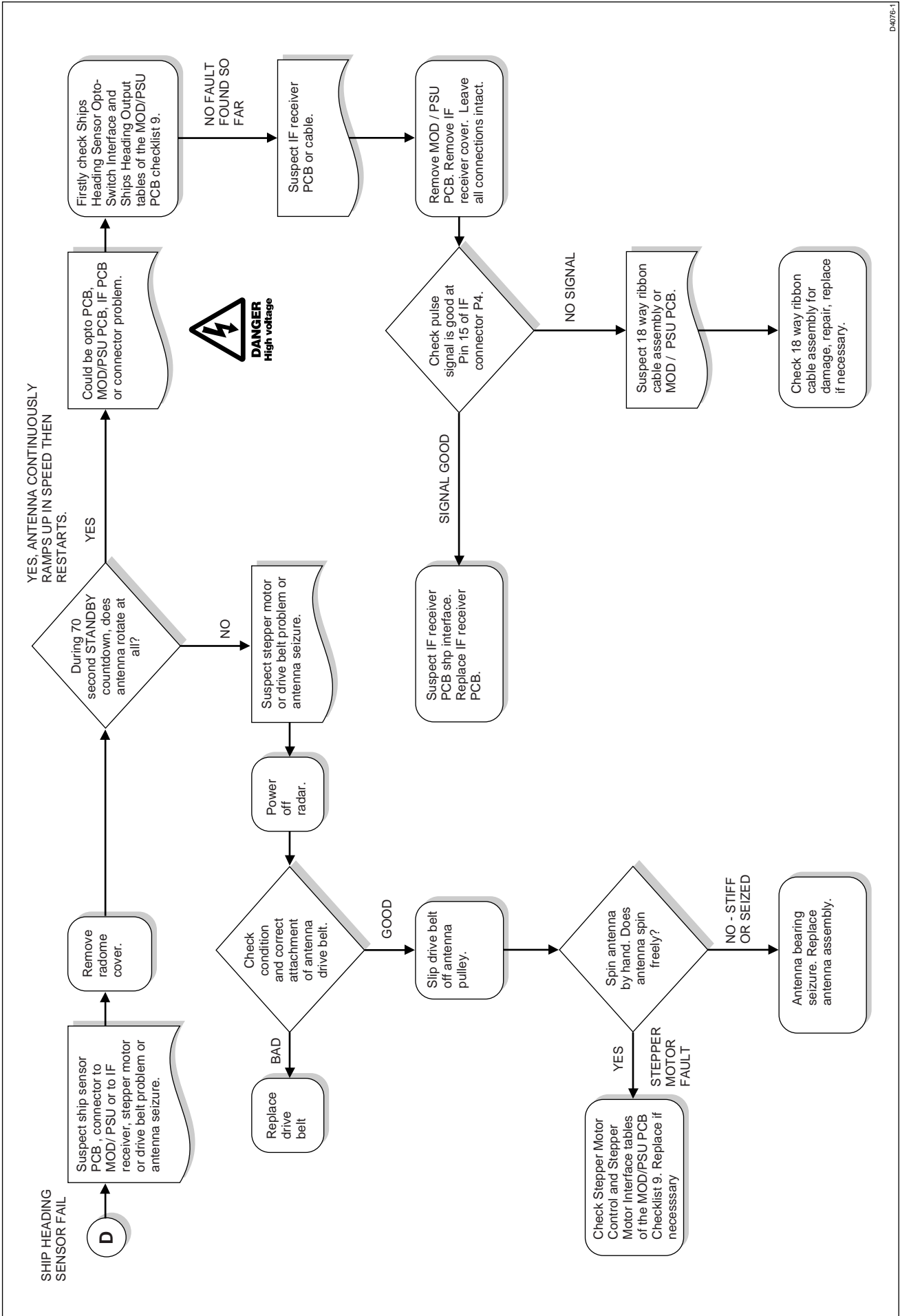

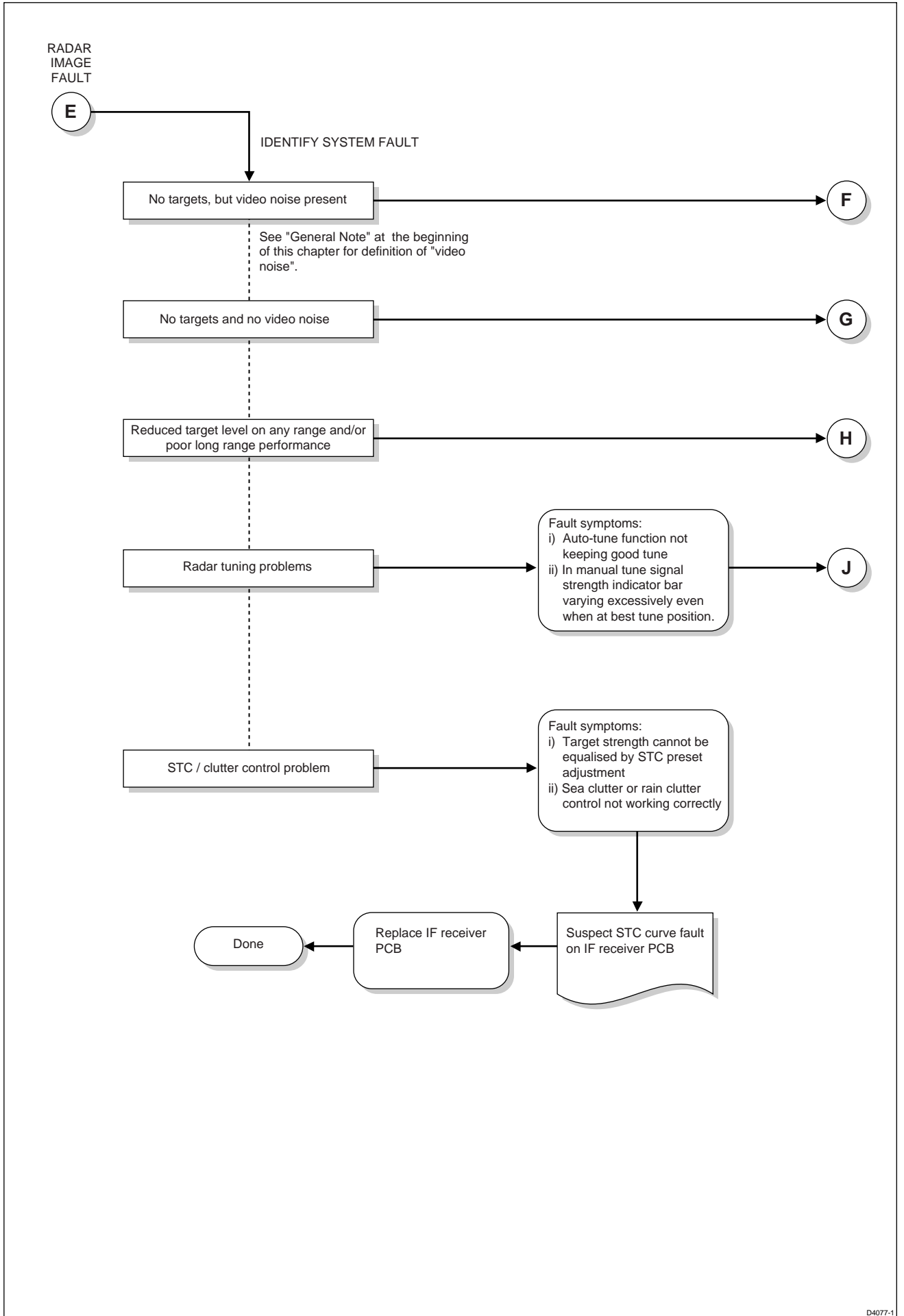

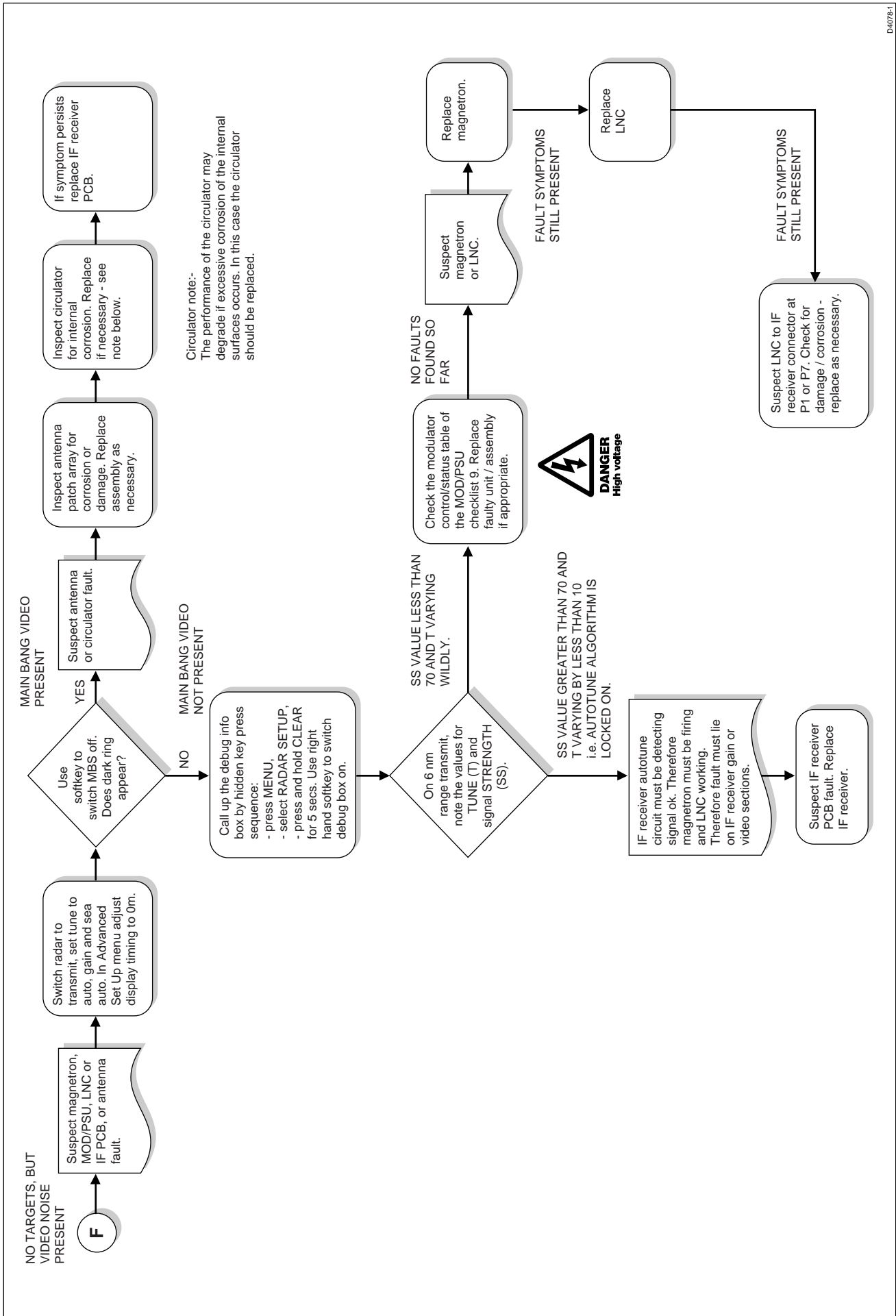

D4076-1

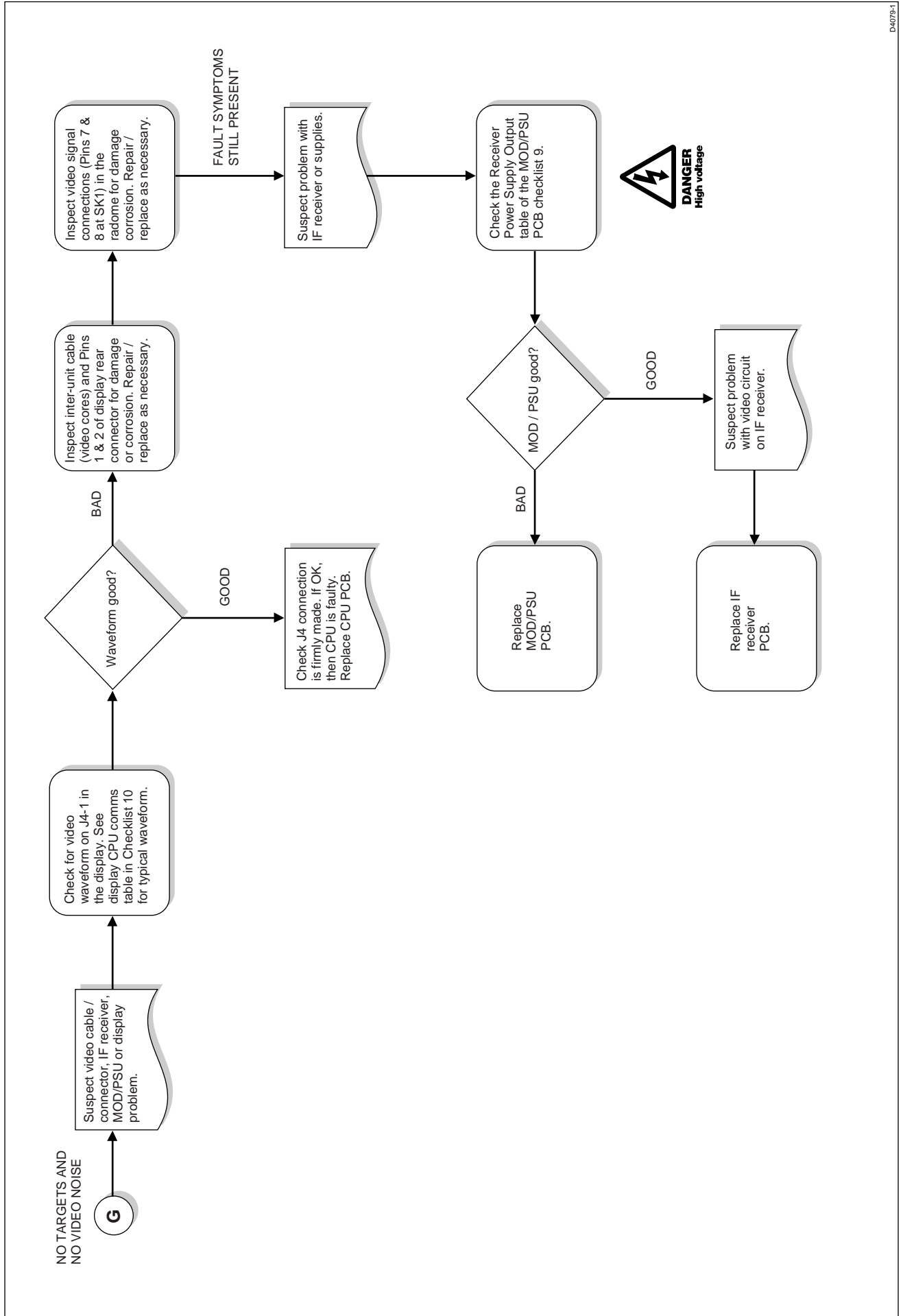

D4079-1

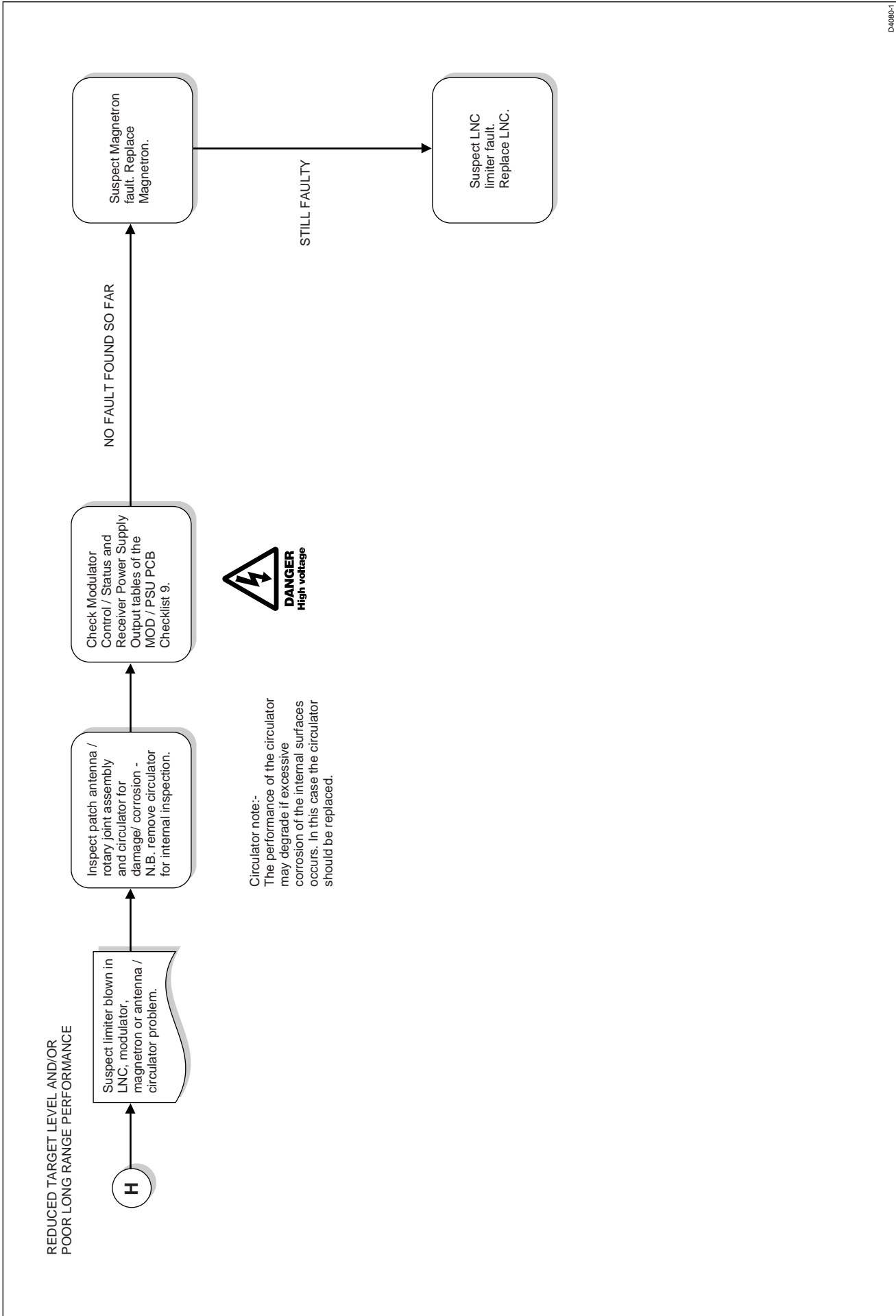

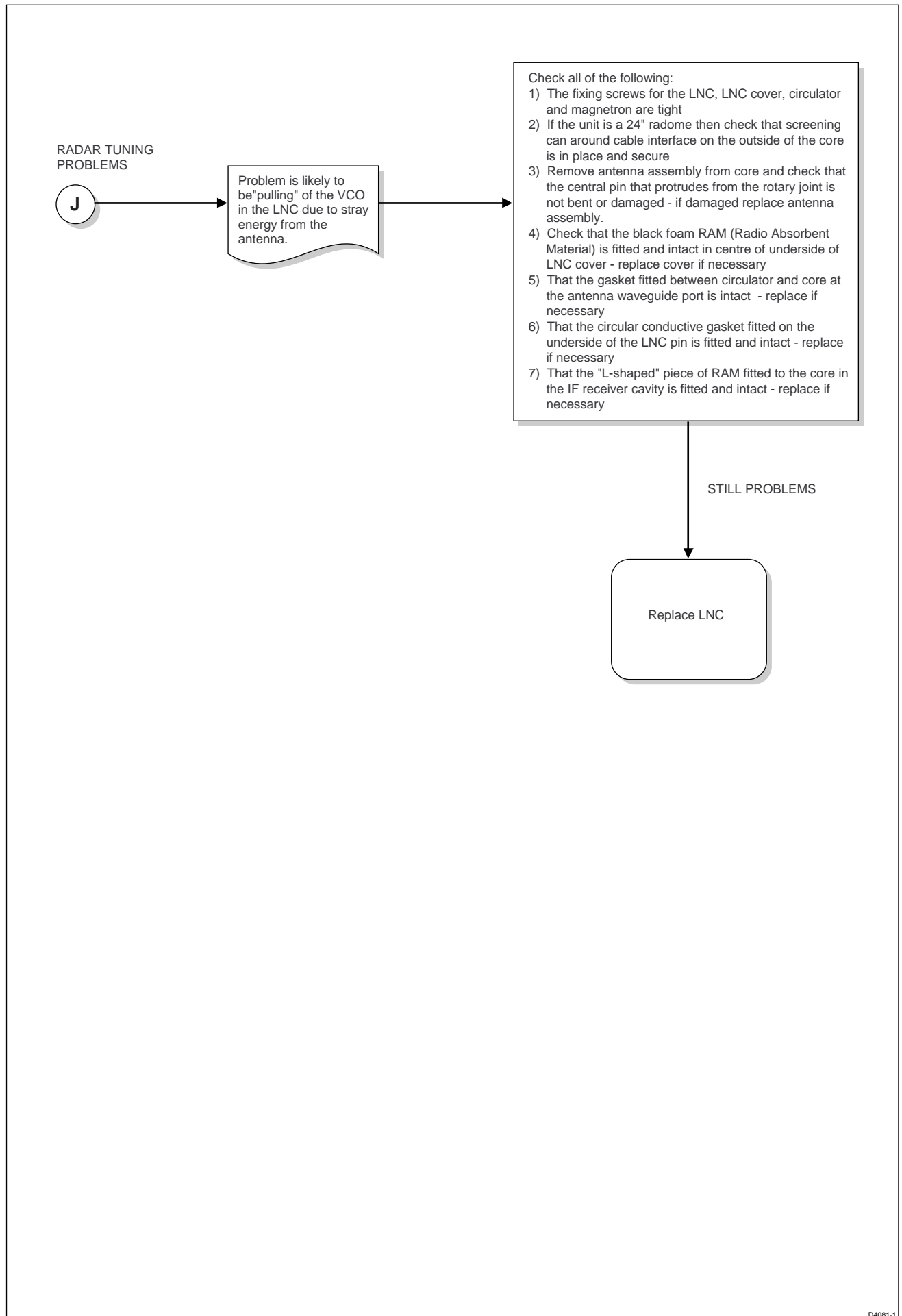

## Check List 9

## MOD/PSU PCB

*General Information*

To allow access to the MOD/PSU interface connections in this checklist the following procedure should be used:

- Turn off the display. Disconnect interunit cable at display.
- Disconnect cable at the Radome and remove Radome to appropriate dry working area or preferably a workshop.
- Remove core assembly from Radome base (N.B. Circular foam seals around core feet will need replacing on reassembly to ensure watertight seal - see general notes at the beginning of this chapter).
- Remove magnetron connector CN6 to ensure transmission, is entirely disabled.
- Invert unit, carefully supporting antenna and remove base cover to expose underside of MOD/PSU PCB. Support unit (e.g. by holding casting gently in a large vice) on its side so that antenna is free to rotate and the MOD/PSU PCB interfaces can be probed. For tests in stand-by mode only, the MOD/PSU PCB may be removed from the core and placed on a suitable insulated surface and the connections re-made to the core remotely, if this is more convenient.
- A spare 10m (light) interunit cable should now be used to connect the core to the display unit.
- Turn power on. **Warning: Dangerous high voltages exist in the core assembly, avoid touching MOD/PSU PCB with fingers whilst powered.**

*Magnetron Dummy Load*

For some of the fault checks in this section it may be required to enable transmit mode to allow proper diagnosis. Due to the hazard from the electromagnetic radiation from the magnetron and antenna this should not be done. However with the magnetron disconnected at CN6, it is safe to connect a dummy load to CN6 to electrically simulate the magnetron load.

A dummy load may be constructed and connected to CN6 as follows :-

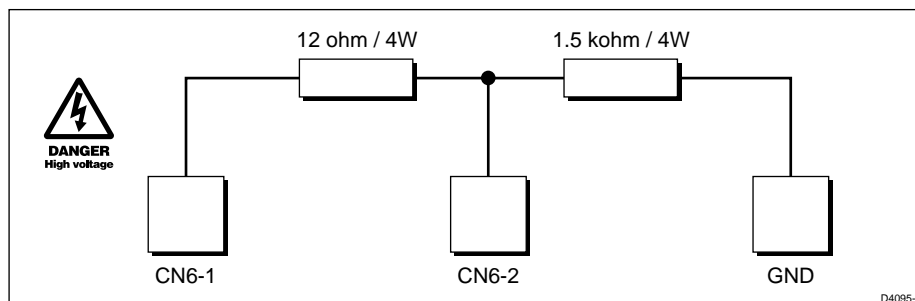

Figure 17. Magnetron dummy load

**Note:** For safety reasons the 1.5k resistor must withstand up to 5 kV pulsed, duty cycle 1/2000. Long wire wound parts will usually suffice. In addition the load should be suitably insulated to prevent High Voltage shocks. The GND connection is to the core casting (the screw fixing for the magnetron cable screen wire adjacent to CN7 socket may be used as a convenient attachment point). The MOD/PSU PCB must be mounted in the core for these tests to ensure adequate grounding.



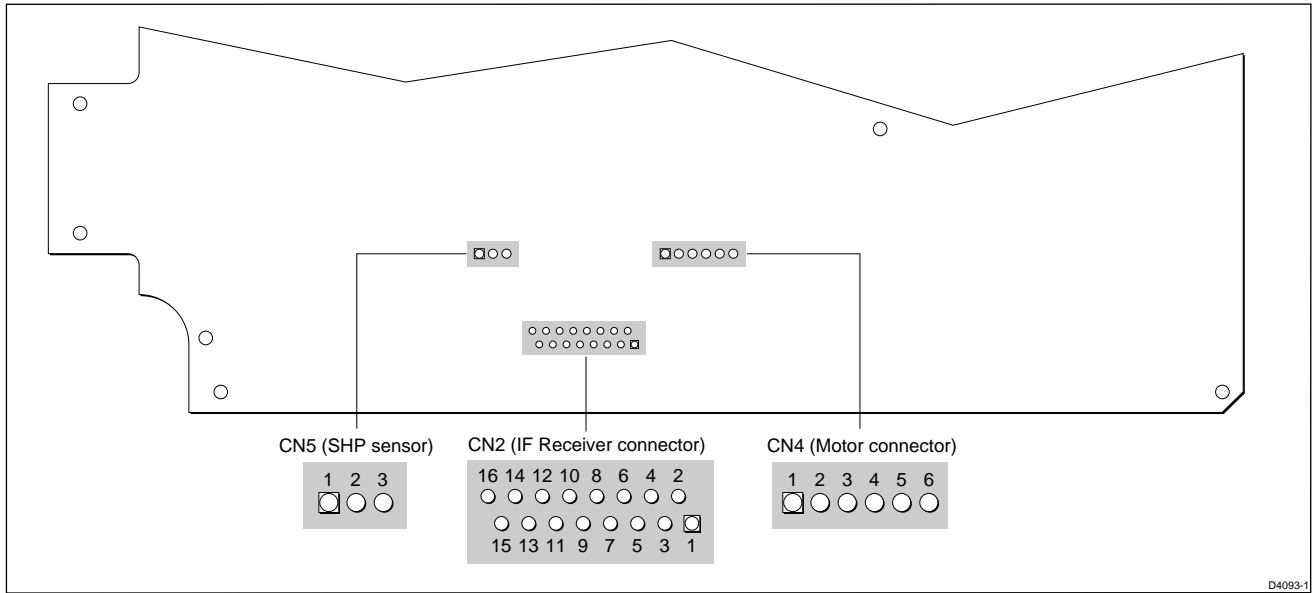

Figure 18. Mod/PSU Connector pins

**Note:** This PCB is conformally coated, thus use of a sharp DVM probe may be required to make a good contact. Pin 1 of each connector is marked with a square pad on the PCB.

In general, perform the check in the order given, or if a particular fault is suspected go to that section.

### Ship Supply Power Input

| Ref.                             | Signal Name | Function           | Status during standby | Fault Checks   |
|----------------------------------|-------------|--------------------|-----------------------|--|
| CN1-5<br>CN1-6<br>CN1-7<br>CN1-8 | +BATT_IN    | Ships power i/p    | 10.7 - 32V            | i) Check Power cores are connected in correct polarity.<br>ii) Check connector for corrosion / poor contacts - repair or replace<br>iii) If voltage is Low - check ship's supply at power cable display socket is within operating spec (>10.7V) and inter unit cable is good - corrosion or damaged cores could cause excessive voltage drop. |
| CN1-1<br>CN1-2<br>CN1-3<br>CN1-4 | -BATT_IN    | Ships power return | -                     | -  |

### Receiver Power Supply Output

| Ref.  | Signal Name | Function                     | Status during standby | Fault Checks  |
|-------|-------------|------------------------------|-----------------------|---|
| CN2-1 | IF-5V       | -5.9V power rail to receiver | -6.4V to -5.6V        | If voltages are out of spec, unstable or not present:   |
| CN2-2 | IF+5V       | +5V power rail to receiver   | 4.7V to 5..3V         | i) Power - off and remove modpsu – disconnect IF receiver ribbon cable  |
| CN2-4 | IF+26V      | +26V power rail to receiver  | 25.0V to 29.0V        | ii) Connect a 10ohm 4W resistor from +5V pin to GND   |
| CN2-6 | IF+12V      | +12V power rail to receiver  | 11.2V to 12.4V        | iii) Power-up and Re - check voltages<br>iv) If still out of spec then mod/psu board low voltage supply is faulty - replace mod/psu board |
| CN2-5 | GND         | Isolated GND return          | GND                   |   |
| CN2-7 | GND         | from receiver power rails    |                       |   |

## Magnetron Interface

| Ref.  | Signal Name | Function                        | Status during standby                                | Fault Checks  |
|-------|-------------|---------------------------------|--|---|
| CN6-1 | HEATER      | Magnetron heater /anode power   | 6.0 to 6.6V across connector (with magnetron fitted) | If voltage out of spec/not present:<br>i) Power-off and disconnect magnetron at CN6, connect a 12 ohm 4W resistor across CN6 socket.  |
| CN6-2 | HEAT/CATH   | Magnetron heater /cathode power |  | ii) Power-up and re-check voltage across connector.<br>iii) If still out of spec then heater supply on mod/psu is faulty - replace mod/psu<br>iv) If OK now then magnetron is faulty. |

## Ships Heading Sensor Opto-coupler Interface

| Ref.  | Signal Name | Function  | Status during standby  | Fault Checks  |
|-------|-------------|---|--|---|
| CN5-1 | BZ          | Opto emitter connection                         | With antenna rotating, signal should normally be high with a low going 100ms pulse once every 2.5 sec's. | No pulse:<br>i) check +5V on pin 2 and GND on pin 3 first<br>ii) check CN5 connector is sound.<br>iii) If OK then faulty opto PCB   |
| CN5-2 | +5V         | +5V to Opto LED anode and collector connection  | 4.7 to 5.3V  | If 5V not present:<br>i) Disconnect opto connector and check Receiver Supply outputs.<br>ii) If supply outputs OK and 5V still not present - faulty mod/psu<br>iii) If 5V now OK then must be a short on opto PCB assembly - replace opto PCB |
| CN5-3 | SHGND       | Current limited Opto LED cathode GND connection | GND  | Check GND continuity  |

## Ships Heading Output

| Ref.   | Signal Name | Function            | Status during standby  | Fault Checks   |
|--------|-------------|---------------------|--|--|
| CN2-15 | SHP_IN      | Output of SHP pulse | With antenna rotating, signal should normally be high with a low going 100ms pulse once every 2.5 sec's. | If signal not present:<br>i) Check CN5 signals OK first<br>ii) If OK then remove IF PCB ribbon cable from CN2 and recheck signal at pin 15<br>iii) If OK now then mod/psu PCB is good.<br>iv) If not replace mod/psu PCB |

## Stepper Motor Control

| Ref.   | Signal Name | Function   | Status during standby  | Fault Checks   |
|--------|-------------|--|--|--|
| CN2-12 | MOTOR_EN_N  | Enable Motor   | Should be low during 70 sec countdown and for 60 sec's afterwards. Else will go high to disable motor. | If not Low;<br>i) Disconnect ribbon connector at CN2 and check pin 12 on cable is low - if not then fault on IF PCB<br>ii) Check connection to CN2 is sound - if OK then fault on mod/psu board - repair or replace  |
| CN2-10 | STEP_IO     | Clock Input Pulses from IF PCB used by the mod/psu to generate Stepper motor drive pulses. | Input from IF PCB at 189 Hz ; 50% duty cycle.  | Motor pulses will only be generated if the IF PCB can see the pull-up resistor fitted to this line on the mod/psu. Therefore:<br>i) Disconnect ribbon connector at CN2 and check pin 10 on the mod/psu is high - if not, then the mod/psu is faulty. Repair or replace.<br>ii) Check IF PCB ribbon cable and connector at CN2 are sound.<br>iii) If sound and still no pulses -fault on IF Receiver PCB. |

### Stepper Motor Interface

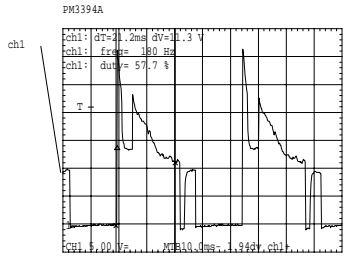
| Ref.  | Signal Name | Function        | Status during standby   | Fault Checks   |
|-------|-------------|-----------------|---|--|
| CN4-6 | STMO1       | Phase A2 switch |  | Whilst motor is enabled see scope trace. If waveform is incorrect or not present check the following:<br>1. Disconnect CN4. Check if motor shaft turns freely by hand. If not, then motor is seized. Replace motor.<br>2. Use an ohm meter to check motor winding resistance. At motor cable connector measure across:<br>Sockets 1 and 2 – 27W<br>Sockets 2 and 3 – 27W<br>Sockets 4 and 5 – 27W<br>Sockets 5 and 6 – 27W<br>If measurement is good, then MOD/PSU is faulty. If measurement is bad, then motor is faulty. |
| CN4-5 | STMO2       | Vmotor          | 11.2V to 12.8V  | If voltage low or not present:<br>i) Disconnect motor connector CN4 and connect a load of 27 ohms (at least 6W rating) from pin 5 or 2 to GND (chassis)<br>ii) Re-check voltage - if still bad then fault with the motor power supply on the mod/ psu<br>iii) If OK then motor faulty - replace motor.   |
| CN4-4 | STMO3       | Phase A1 switch | See CN4-6   | See CN4-6  |
| CN4-3 | STMO4       | Phase B1 switch | See CN4-6   | See CN4-6  |
| CN4-2 | STMO5       | Vmotor          | See CN4-5   | See CN4-5  |
| CN4-1 | STMO6       | Phase B2 switch | See CN4-6   | See CN4-6  |

### PSU Control/Status

| Ref.   | Signal Name | Function  | Status during standby                                   | Fault Checks  |
|--------|-------------|---|---|---|
| CN2-14 | HEATER_EN_N | Enable magnetron heater, modulator PSU and stepper motor PSU. | Should be Logic Low input in standby and transmit modes | If not Low:<br>i) Disconnect ribbon connector at CN2 and check pin 14 on cable is low - if not then fault on IF PCB<br>ii) Check connection to CN2 is sound - if OK then fault on mod/psu board - repair or replace |

Part 2 Chapter 3

## Modulator Control/Status

| Ref.            | Signal Name | Function   | Status during standby  | Fault Checks   |
|-----------------|-------------|--|--|--|
| CN2-18          | RADAR_TX_EN | Enable modulator (magnetron) transmission - input from IF PCB  | This is Low during standby, High in transmit mode  | With a dummy load attached to CN7, check that signal goes High in transmit mode. If not faulty IF board .  |
| CN2-9<br>CN2-11 | PW0,<br>PW1 | Selects modulator pulse width as follows :-<br>80ns pulse (1/8 to 3/4 nm range)<br>250ns pulse (1.5 and 3 nm range)<br>700ns pulse (6nm to max range)<br>700ns pulse (not used)                          | <i>PW0</i> <i>PW1</i><br>0        0<br>1        0<br>0        1<br>1        1                          | Check PW0 and PW1 are of correct status for the range selected, if not:<br>i) Check CN2 cable and connector are sound<br>ii) If not - faulty IF board  |
| CN2-8           | PRI_PLS     | Normally high ,10us+/-0.5us low going pulse. Frequency will be varied according to pulse width;<br>80ns PRF = 2250Hz ;<br>200ns PRF=1500Hz,<br>700ns PRF=750Hz.<br>Rising edge triggers modulator pulse. | This signal is not visible during the 70 second countdown but is switched for the next 60 seconds.     | During 60 second on period if signal is not present:<br>i) Check CN2 cable and connector are sound<br>ii) If not - faulty IF board   |
| CN2-3           | HEATER_OK   | An output which indicates that magnetron heater is connected and drawing > minimum current.  | Should be a logic High in standby and transmit modes   | If signal is Low:<br>i) Check heater voltage on CN7 first<br>ii) If OK then connect a 12ohm 4W resistor across CN7 socket and re-check CN2-3 voltage<br>iii) If still bad disconnect IF ribbon cable and recheck CN2-3.<br>iv) If still bad then Mod/psu PCB is faulty, if OK then fault at IF receiver (short). |
| CN2-17          | MOD_ISENSE  | Indicates peak magnitude of magnetron anode current and thus indicates approximately peak R.F. power output.   | This should be low in standby. In transmit mode refer to Modulator Technical Description in Chapter 2. | Connect a dummy load to CN7. In transmit mode check voltage is in the range as in Figure 7, in Chapter 2.  |
| CN2-16          | MOD_SENSE1  | Analogue voltage indicates build standard.   | N/A  | –  |
| CN2-13          | MOD_SENSE2  | Analogue voltage indicates build standard.   | N/A  | –  |

**Note:** With V1.14 Scanner Micro Software the modulator current readings in the diagnostics menu are incorrect. In this case check the voltage at Pin 17 CN2 of MOD/ PSU PCB. The voltage should be within the limits given in the modulator technical description (Chapter 2) for MOD\_ISENSE. The unit must be powered and in transmit mode, but ensure magnetron connector CN7 is disconnected and connect dummy load at CN7. Unit must be carefully supported to allow antenna to rotate.

### 3.6 Diagnostics Menu – detailed description

The diagnostics menu can be enabled as follows: Press MENU → Press RADAR SET UP or CHART SET UP → Press and hold ENTER (for 5 seconds) → Press BUILT-IN TEST

The menu lists the status of the following items:

1. SCANNER BUILD STD RC520, or a repeater display will only show data for these items marked\*.
2. SCANNER SW VERSION
3. ESN \*
4. DISPLAY SW VERSION \*
5. SCANNER SIZE
6. MODULATOR POWER
7. HEATER HOUR COUNT
8. DISPLAY COMMS \*
9. CABLE TEST STATUS
10. RECEIVER SUPPLY 12V
11. RECEIVER SUPPLY -5.9V
12. RECEIVER SUPPLY 5V
13. SCANNER RESET
14. SHIP HEADING SENSOR
15. MAGNETRON HEATER
16. EEPROMWRITE
17. EEPROM READ
17. FACTORY SETUP
19. IFTUNED
20. MODULATOR CURRENT SP
21. MODULATOR CURRENT MP
22. MODULATOR CURRENT LP
23. ROTATION TIME
24. STC PRESET MAX

In general the status is updated each time that the menu is selected, such that the latest status is shown where appropriate. In the description below the timing of when the items are monitored is given.

### 1. SCANNER BUILD STD.

This item indicates the build standard of the Radar scanner (radome) that the display is connected to. It is in effect a serial number that allows Raytheon to determine the Date of manufacture and exact hardware build standard of the unit. It should be quoted on all Fault Feedback Forms returned to Raytheon. This item is stored in the EEprom of the IF receiver PCB in the scanner, it is read from the scanner once only at power-up.

### 2. SCANNER SW VERSION

This item indicates the software version number of the microcontroller on the IF receiver PCB in the scanner. This item is stored in the EEprom of the IF receiver PCB in the scanner, it is read from the scanner once only at power-up.

### 3. ESN

Display Electronic Serial Number. This item indicates the build standard of the Radar display unit. It is in effect a serial number that allows Raytheon to determine the Date of manufacture and exact hardware build standard of the unit. It should be quoted on all Fault Feedback Forms returned to Raytheon.

### 4. DISPLAY SW VERSION

This item indicates the software version of the PROMs on the CPU PCB in the display unit. It is read once only at power-up.

### 5. SCANNER SIZE

This item indicates the size of the radome antenna in inches. This item is stored in the EEprom of the IF receiver PCB in the scanner, it is read from the scanner once only at power-up.

### 6. MODULATOR POWER

This item indicates the output power of the radome modulator and Magnetron in kW. This item is stored in the EEprom of the IF receiver PCB in the scanner, it is read from the scanner once only at power-up.

### 7. HEATER HOUR COUNT

This item indicates the number of hours that the magnetron heater has been running for throughout the Radar systems' life i.e. the sum of the standby and transmit hours. It is incremented every 6 minutes (0.1 hour). This item is stored in the EEprom of the IF receiver PCB in the scanner, it is read from the scanner once only at power-up.

### 8. DISPLAY COMMS

A display communications test is performed at power-up to check the display to scanner communications link driver is functioning OK. If this shows a FAIL status then a SCANNER NOT RESPONDING message will be shown on power-up. Refer to Checklist 2 for further diagnosis.

### 9. CABLE TEST STATUS

This item shows the status of the cable test function. This test checks that the PRI differential pair and the AZimuth\_SHP pair of wires linking the display to the scanner are making a good connection. If a FAIL status is indicated check the condition of the inter-unit cable and the 8-way

Molex connector at SK1 in the Radome (pins 1 and 2, 5 and 6). See flowchart for further diagnosis. This test is performed once at power up only.

**NOTE: Failure Symptoms.** Failure of one of the AZ\_SHP pair of wires (pins 1 and 2) can give an effect in the Radar picture where certain sectors of the screen are updated rapidly while other are “frozen” or blank. If both fail then no radar picture or video noise is seen.

Failure of one of the PRI links (pins 5 and 6), can give a “spoke type” interference effect in the Radar picture, with possibly a blank “hole” in the centre of the screen up to approximately 0.7nm range. If both fail then no radar picture or video noise will be seen.

### *10, 11, 12. RECEIVER SUPPLY (12V, -5.9V and 5V)*

This test checks the presence of the above supply voltages at the IF receiver. The test is performed once, each time that transmit mode is entered. If the diagnostics menu is entered before transmitting then these items will indicate NOT TESTED. The 12V and 5V tests are on the switched rails of the IF receiver. Failure of 5V indicates an IF board problem, the 12V either a MOD/PSU, ribbon cable or IF Receiver problem, and -5.9V most likely a MOD/PSU or ribbon cable problem. See flowchart for further diagnosis.

### *13. SCANNER RESET*

When the Radar system is powered up the scanner is in a reset state which the display acknowledges and then initialises operation. If the power supply to the Radar system is interrupted (ship's supply fault) or the scanners' own PSU goes faulty, it can Reset again. This menu item logs the number of times that the scanner has reset since power up. During normal operation this should be zero.

If it is not zero then a fault with the MOD/PSU PCB in the scanner may be the cause, or a Magnetron failure causing a short circuit on the PSU's High voltage output and thus causing the PSU to continually reset. See Flowchart B.

### *14. SHIP HEADING SENSOR*

This test checks the presence of Ships Heading Pulses from the opto PCB in the radome, which should be once per revolution of the antenna. A FAIL status could either be a failure of the opto PCB, cable connector etc. Or failure of rotation of the antenna, possibly a Stepper motor problem, belt drive failure or antenna seizure. See flow chart for further diagnosis. The test is part of a combined Status Report 1 test and is performed once every 4 sec's.

### *15. MAGNETRON HEATER*

This test detects the presence of current being drawn by the Magnetron heater during standby and transmit operation. The detection circuit uses a differential transistor pair (Q62 and Q63 - sheet 3 of the circuit diagram) on the MOD/PSU PCB to monitor the current. If a FAIL status is indicated the most likely cause is that the magnetron heater wire(s) are disconnected /damaged/ corroded at connector CN6 of the MOD/PSU PCB. Alternatively, failure of the PSU units 6.3V heater supply is suspected. This test is also part of the combined Status Report 1 test and is performed once every 4 sec's.

### 16, 17. EEPROM WRITE/READ

If a FAIL status is indicated it means an error has occurred with a read or write operation from the scanner EEPROM within the last 4 seconds (i.e. since the test was last performed, as this test is also part of the combined Status Report 1 test which is performed once every 4 sec's). It is unlikely that an intermittent or occasional error would occur, and as the information is updated at 4 sec intervals the service engineer is unlikely to enter the menu at the right time to spot such errors.

Therefore if a FAIL is indicated check the following:

Read errors:

- The majority of the EEPROM read operations occur at initial power up. A read failure would mean that the display would not show correct scanner description information ( size, power, build standard etc.) and the automatic TUNE function would not work.

Write errors:

- The display writes to the scanner EEPROM when the transmit pulse length is changed (e.g. from 3/4 to 1 1/2 nm and from 3nm to 6nm) to store the current FINE TUNE value for the automatic tune function . To check operation, switch on the radar and allow to warm up for ten minutes with the TUNE function in automatic mode (in short pulse 3/4 nm range for example). Now switch to medium range (1 1/2 nm), the display should take a few rotations to reach optimum TUNE. Now switch back to short range - the display should be tuned instantly - a delay in tuning could indicate an EEPROM write failure.
- The other write operations occur when the ADVANCED SET-UP menu items are adjusted and if the SCANNER SETTINGS hidden menu items are changed. A write failure here would be indicated if the newly adjusted value is lost when the unit is powered off and on again.

In either case, the scanner IF Receiver PCB should be replaced.

### 18, 19. FACTORY SETUP / IF TUNED

These tests are performed simultaneously, once only when the system is powered up. They check that the IF receiver PCB in the scanner has been set up correctly at the factory. These items should always be PASS unless the EEPROM has become corrupted or if by some event an incorrect IF receiver PCB is fitted. In any case, if either indicate a FAIL then the scanner IF Receiver PCB should be replaced.

### 20, 21, 22. MODULATOR CURRENT (SP, MP, LP)

When the Radar is running in transmit mode, the display monitors the modulator current that the magnetron is drawing for each pulse length that has been used. This value is then displayed next to the appropriate pulse length ( SP = short pulse, MP = medium pulse, LP = Long pulse). If a particular pulse length has not been used yet then it indicates NOT TESTED.

If there are no Radar target returns on the display or "poor" radar performance is experienced referring to these values may indicate if there is a magnetron problem or not.



The readings should lie within the ranges given in the table below:

| Scanner Power | Pulse Length | PASS Range |
|---------------|--------------|------------|
| 2kW           | SP           | 96-153     |
|               | MP           | 112-153    |
|               | LP           | 112-153    |
| 4kW           | SP           | 66-123     |
|               | MP           | 81-123     |
|               | LP           | 91-123     |

Figure 19. Modulator current

### 23. ROTATION TIME

This item shows the measured rotation time of the scanner. The scanner rotates at a nominal 24 rpm, so the nominal rotation time should be 2,500 milliseconds. This provides another useful indication that the antenna is indeed rotating correctly inside the radome. A gross error in the timing would indicate the same problems as for the Ship's Heading Sensor item.

### 24. STC PRESET MAX

This item displays the factory set STC curve level. If an STC curve problem is suspected ( e.g. targets fading as they come closer in range to the vessel) then the "used" STC curve level may be adjusted from the Advanced Settings Menu. A factory reset should be performed before making any adjustments to ensure that the scanner is in its correct initial state. Ensure that the scanner is connected during this operation.

To perform a factory reset: Put the Radar in stand-by mode, press the MENU key. Press the SYSTEM-SET UP soft key, press and hold MENU for 5 seconds.



## Chapter 4. Setting-up Procedures

### 4.1 Fitting of Replacement IF Receiver PCB

If a new IF PCB is fitted to the Radar scanner as the result of a service operation, it will not have the scanner size and Modulator Power items stored in its EEPROM (as the IF receiver is supplied as a common Spares item for all Pathfinder Radars). In this case the service engineer should set these by using the following procedure:

- Select Scanner Settings Menu by following “hidden” key press:
- Press MENU
- Select RADAR SET UP
- Press and hold CLEAR for approx. 5 secs
- Select SCANNER SETTINGS soft-key
- Scroll down the Menu using the trackpad and adjust the Scanner Size and Modulator Power using the softkeys.
- For current systems, the RL72/RL72RC is 18" and 2KW, the RL74/RL74RC is 24" and 4KW.
- Press ENTER to store the values and leave the menu.
- Check that the maximum selectable Radar range is now 24nm (RL72/RL72RC) and 48nm (RL/RL74/RL74RC).

The IF PCB also stores the Bearing Alignment, Display Timing and Tune Preset Data. These items should be checked and adjusted as necessary. This is described below.

### 4.2 Fitting of Replacement Magnetron or LNC

If a new Magnetron or LNC is fitted as the result of a service operation, the Tune preset setting may need to be adjusted.

**Important:** The Magnetrons fitted to these radars will be either of Toshiba or NJRC manufacturer. If a magnetron is to be replaced, one of the same type and same manufacturer must be selected.

### 4.3 Bearing Alignment

The bearing alignment is normally set when you first install your system, and is described in Section 6.9, Bearing Alignment, of the Owner's Handbook. It should be checked periodically.

The bearing alignment corrects for display azimuth error. It can be set to a value in the range  $-180^{\circ}$  to  $+180^{\circ}$ , in increments of  $0.5^{\circ}$ .

### 4.4 Display Timing

If you extended the inter-unit cable, you should have set the display timing when you first installed your system, as described in Section 6.9, Display Timing Adjustment of the Owner's Handbook. This will need to be repeated (for extended inter-unit cables) if the Scanner Reset has been carried out.

If you wish to turn off Main Bang Suppression when adjusting the display timing, press the MBS soft key to toggle the setting. MBS is reset to ON automatically when you finish adjusting the display timing.

## 4.5 Tune Preset

If the IF receiver PCB, LNC assembly, or the Magnetron has been replaced, then the Tune Preset should be checked and adjusted if necessary as described in Section 5.5, Tune Preset of the Owner's Handbook.

## Chapter 5 . Replacement Parts

This chapter contains the Spare Parts Lists for the 18" and 24" radar scanner units. This is followed by a number of notes on how to obtain access to specific parts and how to replace them. Generally identification of parts and their replacement can be carried out by referring to the exploded view drawings at the rear of this chapter.

### 5.1 Spare Parts Lists

#### 18" Radar Scanner Unit

When ordering spares, quote the **Spare Description**, prefixed by **18" Radar** and the **Part No.**

The **Item** numbers refer to Figure 20: 18" and 24" Scanner Unit.

| Item | Spare Description   | Part No. | Comment         |
|------|---|----------|-----------------|
|      | Top cover 'Raytheon', <i>including:</i><br>18" Radome top<br>Square shoulder nut (x4)<br>Radome label set   | W101     | Not illustrated |
| 1    | Base. <i>including:</i><br>18" Radome Base<br>Cable clamp<br>Screw, M4 x 16 (x2)<br>Cable gland<br>Nylon lock nut<br>Cable gland washer<br>Rating label | W103     |                 |
| 2    | Case Seal   | R085     |                 |
| 3    | Antenna & Rotary Joint, <i>including:</i><br>Rotary joint sub-assembly<br>Protection cap  | R086     |                 |

#### 24" Radar Scanner Unit

When ordering spares, quote the **Spare Description**, prefixed by **24" Radar** and the **Part No.**

The **Item** numbers refer to Figure 20: 18" and 24" Scanner Unit.

| Item | Spare Description   | Part No. | Comment         |
|------|---|----------|-----------------|
|      | Top Cover 'Raytheon', <i>including:</i><br>24" Radome top<br>Square shoulder nut (x4)<br>Radome label set   | W105     | Not illustrated |
| 1    | Base, <i>including:</i><br>24" Radome base<br>Cable clamp<br>Screw, M4 x 16 (x2)<br>Cable gland<br>Nylon lock nut<br>Cable gland washer<br>Rating label | W107     |                 |
| 2    | Case Seal   | R087     |                 |
| 3    | Antenna & Rotary Joint, <i>including:</i><br>Rotary joint sub-assembly<br>Protection cap  | R088     |                 |

## Radar Core Assembly

When ordering spares, quote **Spare Description** (prefixed by **Radar** for items 4 to 16 ) and the **Part No.** The **Item** numbers refer to Figures 20 and 21: 18" and 24" Scanner Unit.

| Item | Spare Description  | Part No. | Comment                            |
|------|--|----------|------------------------------------|
| 5.1  | Core Seals, <i>including:</i><br>Core Seal   | R089     |                                    |
| 5.2  | 'O' Ring (x4)  |          |                                    |
| 5.3  | Foot seal (x4)   |          | Also item 19                       |
| 6.1  | Magnetron 2kW Toshiba, <i>including:</i><br>Magnetron 2kW  | R090     |                                    |
| 6.2  | Rubber boot<br>Connector housing<br>Terminal (x2)<br>Sleeve, 175mm<br>Cable screen   |          |                                    |
| 6.1  | Magnetron 2kW NJRC <i>including:</i><br>Magnetron 2kW  | R58006   |                                    |
| 6.2  | Rubber boot<br>Connector housing<br>Terminal (x2)<br>Sleeve, 175mm<br>Cable screen   |          |                                    |
| 6.1  | Magnetron 4kW Assy, <i>including:</i><br>Magnetron 4kW   | R091     |                                    |
| 6.2  | Rubber boot<br>Connector housing<br>Terminal (x2)<br>Sleeve, 175mm<br>Cable screen   |          |                                    |
| 7    | Circulator   | R094     |                                    |
| 8    | Stepper motor, <i>including:</i><br>Stepper Motor<br>Terminal (x6)<br>Connector housing<br>Drive pulley<br>Sleeving, 180mm | R095     |                                    |
| 9    | Drive belt   | R096     |                                    |
| 10   | Opto PCB assembly, <i>including:</i><br>Opto PCB & cable assembly<br>Cable tie   | R104     |                                    |
| 11   | LNC PCB Assy, <i>including:</i><br>Receiver LNC PCB<br>Receiver RAM<br>LNC screen lid<br>Conductive washer                 | R101     |                                    |
| 12   | LNC Connector assembly   | R105     | Moulded connector assembly (to IF) |
| 13   | Modulator PCB 2KW Toshiba  | R097     |                                    |
| 13   | Modulator PCB 2KW NJRC   | R58007   |                                    |
| 13   | Modulator PCB 4kW  | R098     |                                    |
| 14   | IF PCB   | R102     | IF PCB and support control         |
| 15   | Core ribbon cable  | R103     | 18 way (modulator to IF)           |
| 16   | IF Cover, <i>including:</i><br>IF Cover and Urethane Tape, 30mm  | R108     |                                    |

|    |  |      |           |
|----|--|------|-----------|
| 17 | Receiver cover and seal, <i>including</i> :<br>Receiver cover<br>Receiver cover seal<br>Receiver RAM | R106 | LNC       |
| 18 | Lower cover and insulator, <i>including</i> :<br>Lower cover and Insulator<br>High voltage label     | R107 | Modulator |

## 18" and 24" Scanner (common spares)

When ordering spares, quote the **Spare Description** and the **Part No.**

The **Item 19** refers to Figure 20: 18" and 24" Scanner Unit.

| Item | Spare Description  | Part No. | Comment             |
|------|--|----------|---------------------|
|      | 18" & 24" Drain tube   | R123     | Not illustrated     |
| 19   | 18" & 24" Foot seal (x4)   | R124     | Also part of item 5 |
|      | 18" & 24" Lanyard, <i>comprising</i> :<br>Polypropylene lanyard, 500mm   | R125     | Not illustrated     |
|      | 18" & 24" Radar fittings pack, <i>including</i> :<br>Bolt - M8 x 40mm (x4)<br>Washer, spring - M8 (x4)<br>Washer - M8 (x4) | W104     | Not illustrated     |
|      | Radome fixing screw kit, <i>including</i> :<br>Case screws (x4)<br>'O' Ring, 3/16 inch ID (x8)<br>Washer - M4 (x4)         | D346     | Not illustrated     |
|      | Radar cable connector kit  | R126     | Not illustrated     |
|      | Bitumen washer (x4)  | R141     | Not illustrated     |

## 4.2 18" and 24" Scanner Units - *replacement of parts*

The following notes supplement the exploded view drawings to assist with access to, or replacement of Parts.

**WARNING: The scanner unit contains high voltages. Before removing the cover switch off the radar and isolate the power source.**

Refer to the scanner units Spare Parts List and the exploded view drawings. Figures 20 and 21.

Replacement of scanner unit parts fall into two categories:

**Category A.** Can be accessed with the scanner installed.

1. Top cover
2. Case Seal
3. Antenna & Rotary Joint
4. Magnetron 2kW, or 4kW
5. Circulator
6. Drive Belt
7. LNC PCB Assembly
8. Drain Tube
9. Lanyard
10. Radar Cable Connector
11. Receiver Cover and Seal

**Category B.** Requires the removal of the scanner, so that the Core can be separated from the Radome Base.

1. Radome Base
2. Core 18" & 24"
3. Stepper Motor \*
4. Opto PCB Assembly \*
5. LNC Connector Assembly \*
6. Modulator PCB 2kW, or 4kW \*
7. IF PCB
8. Core Ribbon Cable
9. IF Cover
10. Lower Cover and Insulator

\*Removal of these items requires actions both inside and outside the core.

**Note:** Fitting and seal kits have been omitted from the above lists.

### Category A

1. *Top Cover.* When refitting the top cover do not over tighten the 4 securing screws (6 lb.in, or 0.7 Nm).
2. *Case Seal.* Always check the condition of the case seal and replace if necessary, before fitting the top cover.
3. *Antenna & Rotary Joint.*

**WARNING: The Antenna must not be separated from the Rotary Joint. Do not unsolder the antenna probe, or release any of the antenna fixings.**

Remove the complete assembly by first releasing the drive belt from the motor pulley wheel. Then remove the 4 screws (item 20) accessed through the holes in the top of the locking ring (which supports the plastic pulley wheel) and lift the complete assembly clear of the core.

Take care not to damage the probe protruding below the rotating joint. The bearings must not be packed with additional grease.

When fitting the antenna & rotating joint, position the drive belt above the plastic pulley wheel, align the flat on the bearing retaining plate with the flat on the core casting and then rotate the locking ring so that the 4 screws can be refitted. Make certain the drive belt is free from dirt or grease and refit to the pulley wheels.

4. *Circulator.*

**WARNING: The Circulator must not be taken apart.**

To remove the circulator slacken the 4 lower screws and remove the 4 upper screws.

When fitting the circulator replace all the screws loosely and then tighten evenly.

5. *Drive Belt.* The Antenna & Rotating Joint must be removed if the drive belt is to be replaced. Ensure the drive belt is free from grease and dirt before fitting.
6. *LNC PCB Assembly.* It is recommended that the antenna & rotary joint is removed (see 3. above) to gain access to the receiver cover screws.

When refitting the LNC PCB assembly take care not to damage the RF probe and ensure that



the conductive washer is in place on the probe. Do not over tighten the 5 securing screws (6 lb.in, or 0.7 Nm).

A new LNC PCB will require the Advanced Settings to be checked and adjusted, if necessary, as detailed in the Owner's Handbook in section 5.5 and 6.9.

7. *Drain Tube.* Fitting of the drain tube is described in the Owner's Handbook, section 6.6, Connecting the Scanner.

### Category B

8. *Core 18" and 24"*

**WARNING: When working on the underside of the core, ensure the antenna is protected from physical damage.**

Replacement of any category 'B' item will necessitate the removal of the core from the radome base. Generally the scanner unit should be removed from its mounting to a safe location by disconnecting and removing the inter-unit cable and releasing the 4 M8 bolts. Protect the end of the inter-unit cable.

The core is then removed by releasing the 4 small securing screws (item 24).

9. *Stepper Motor.* To disconnect the motor cable remove the lower cover and insulator (see 13. below) and the modulator PCB.
10. *Opto PCB Assembly.* It is recommended that the antenna and rotary joint is first removed (see 3. on page 50) to obtain access to the opto PCB. To disconnect the opto PCB cable remove the lower cover and insulator (see 13. below) and the modulator PCB.
11. *LNC Connector.* First remove the antenna & rotary joint (see 3. on page 50), the receiver cover and seal and the LNC PCB assembly (see 6. on page 50). Next remove the lower cover and insulator (see 13. below), modulator PCB, IF cover and IF PCB.
12. *IF PCB.* If a new IF PCB is fitted, then the Bearing Alignment and Advanced Settings should be checked and adjusted as necessary as detailed in the Owner's Handbook section 5.5 and 6.9.
13. *Lower Cover and Insulator.* When refitting the lower cover to the core ensure that the insulated section is placed over the high voltage part of the modulator PCB.

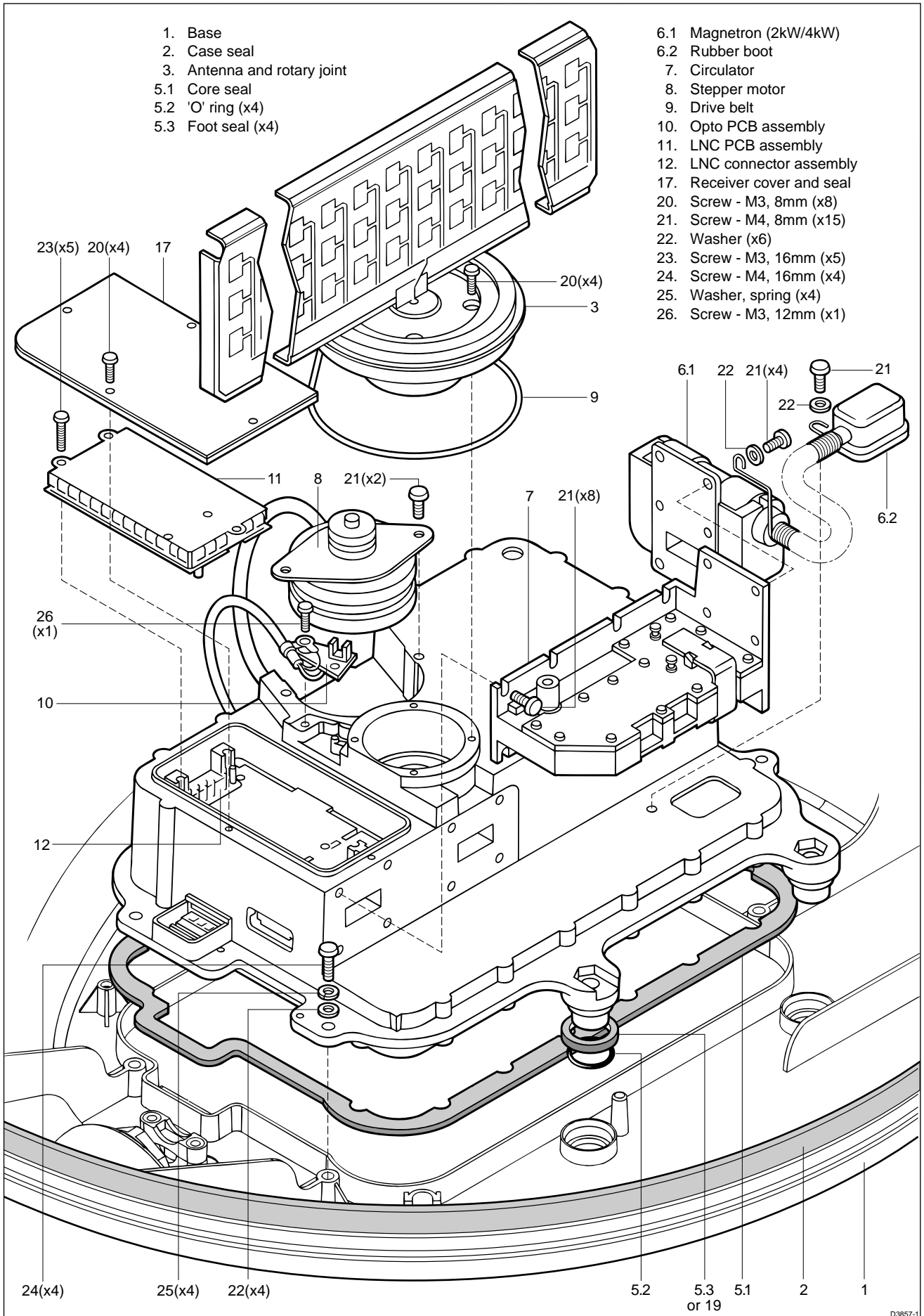

D3857-1

Figure 20. 18" & 24" scanner

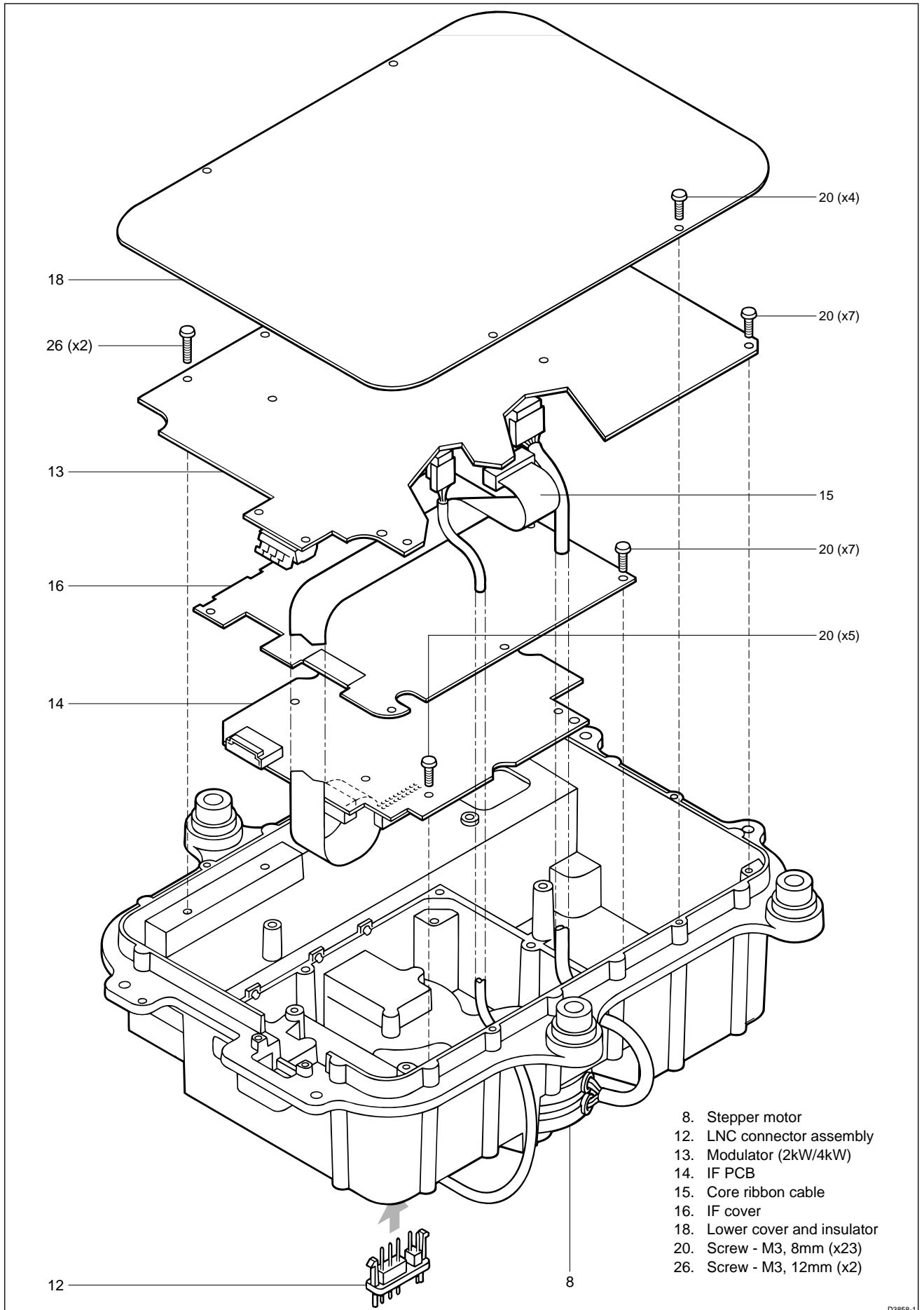

Figure 21. 18" & 24" scanner



## Chapter 6. Drawings

### List of drawings

|  |    |
|--|----|
| 18" (2kW) and 24" (4kW) Scanner Interconnections .....       | 56 |
| Modulator/PSU Board – Top level .....                        | 57 |
| Modulator/PSU Board – Low Voltage PSU .....                  | 58 |
| Modulator/PSU Board – High Voltage PSU .....                 | 59 |
| Modulator/PSU Board – Modulator .....                        | 60 |
| Modulator/PSU Board – 3 Phase DC brushless motor drive ..... | 61 |
| Modulator/PSU Board – Stepper Motor Drive .....              | 62 |
| Modulator/PSU Board – PCB layout (2kW, stepper motor) .....  | 63 |
| Modulator/PSU Board – PCB layout (4kW, stepper motor) .....  | 64 |
| IF Receiver – Top level .....                                | 65 |
| IF Receiver – PCB Layout .....                               | 66 |

18" (2kW) and 24" (4kW) Scanner Interconnections

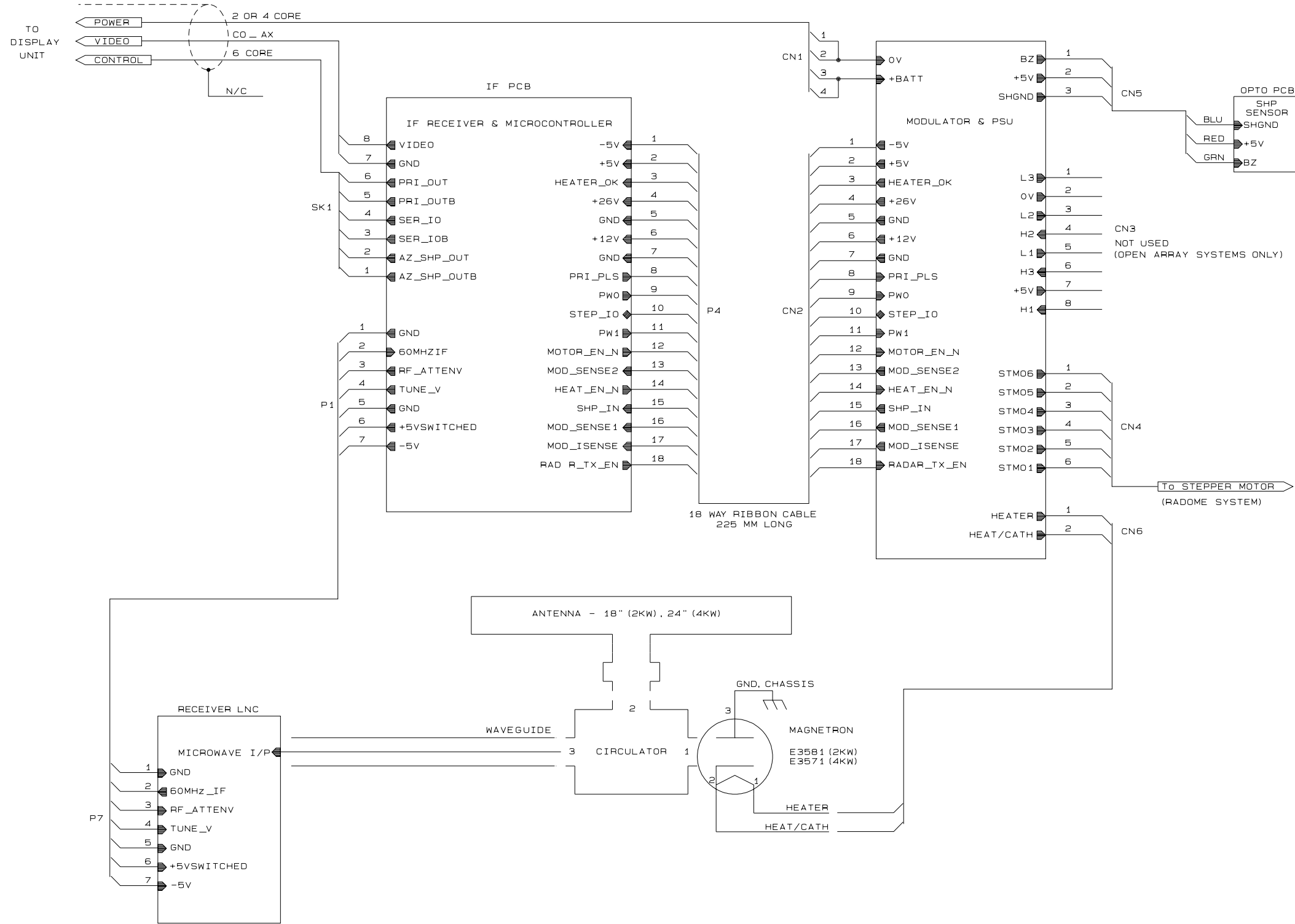

|  |       |  |
|--|-------|--|
| TITLE  |       |  |
| 18"(2KW) and 24"(4KW) SCANNER INTERCONNECTIONS |       |  |
| DERIVED FROM DRAWING No.                       | ISSUE |  |
| 4346 - 027                                     | A     |  |

D3853-2

Part 2  
Chapter 6

Modulator/PSU Board – Top level

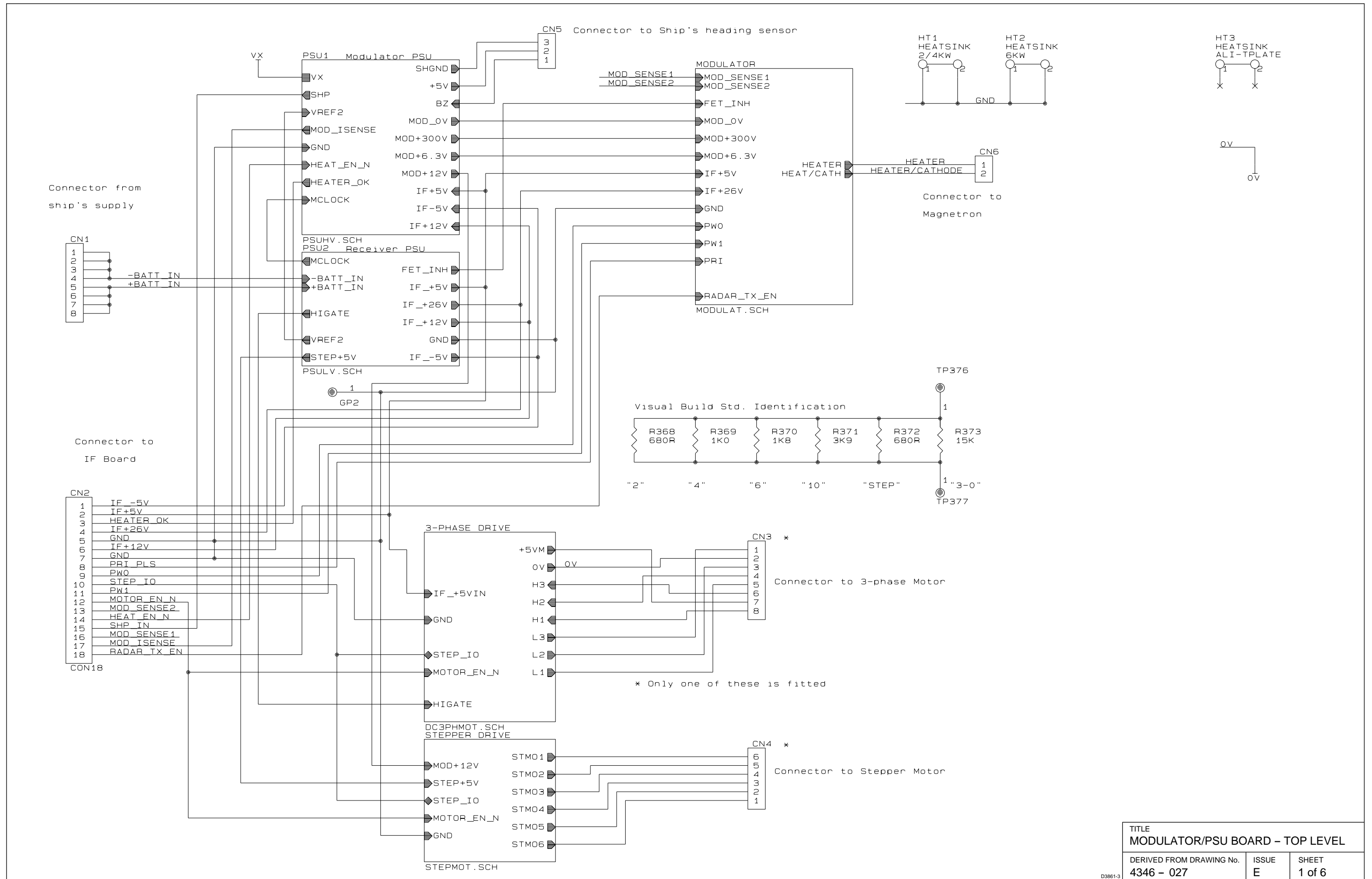

|  |            |                 |
|--|------------|-----------------|
| TITLE<br>MODULATOR/PSU BOARD – TOP LEVEL |            |                 |
| DERIVED FROM DRAWING No.<br>4346 – 027   | ISSUE<br>E | SHEET<br>1 of 6 |

D3861-3

Modulator/PSU Board - Low Voltage PSU

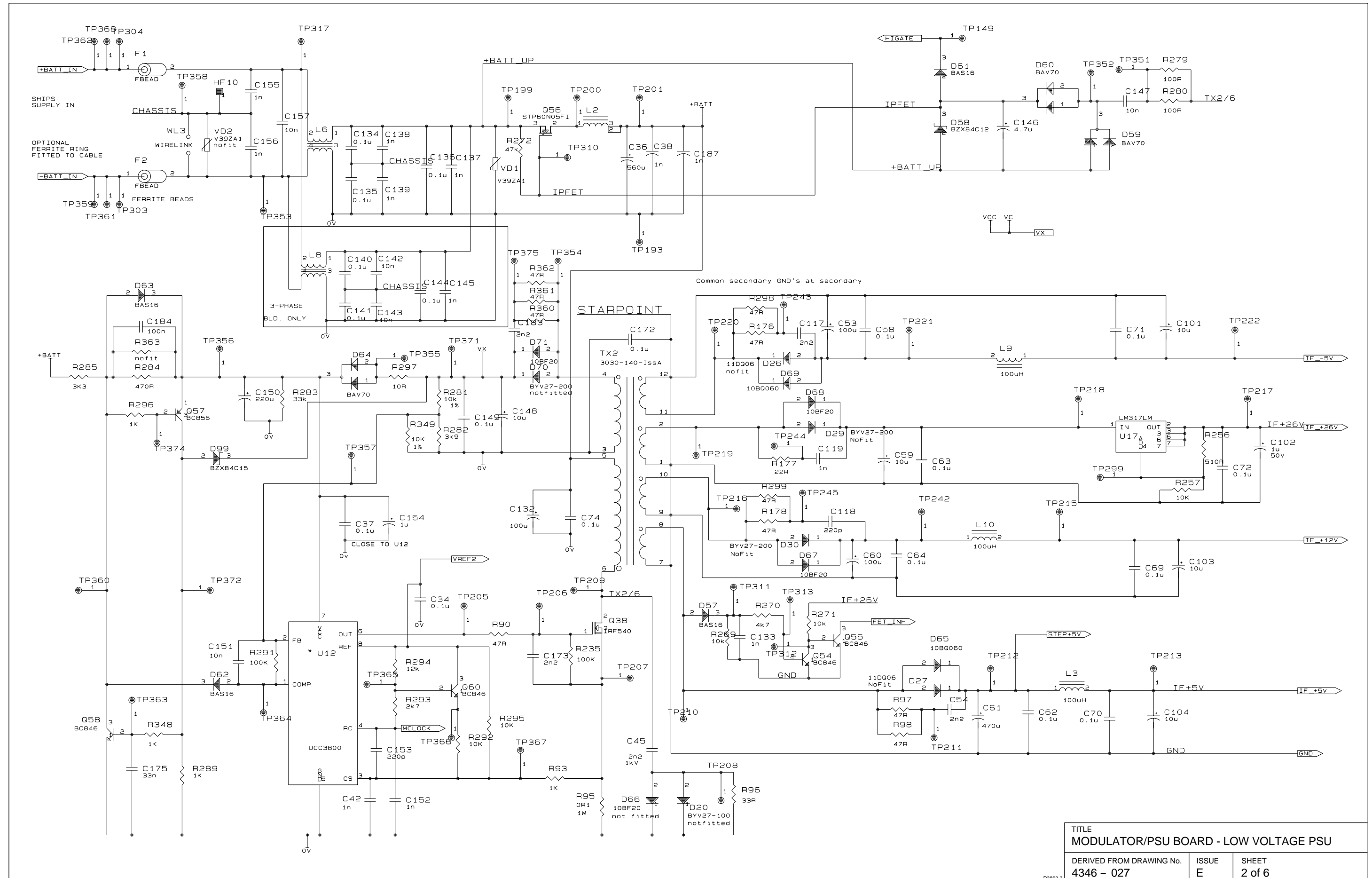

|  |            |                 |
|--|------------|-----------------|
| TITLE<br>MODULATOR/PSU BOARD - LOW VOLTAGE PSU |            |                 |
| DERIVED FROM DRAWING No.<br>4346 - 027         | ISSUE<br>E | SHEET<br>2 of 6 |

Part 2  
Chapter 6



Modulator/PSU Board – High Voltage PSU

NOTE: CT1, D16, R85 fitted on 6 and 10KW versions only  
R179 fitted on entry level only (JP14 linked)

NOTE 2: For entry level fit JP1  
- do not fit D24, R173, R174, C49, C115  
For 6 and 10KW fit JP2 and above components

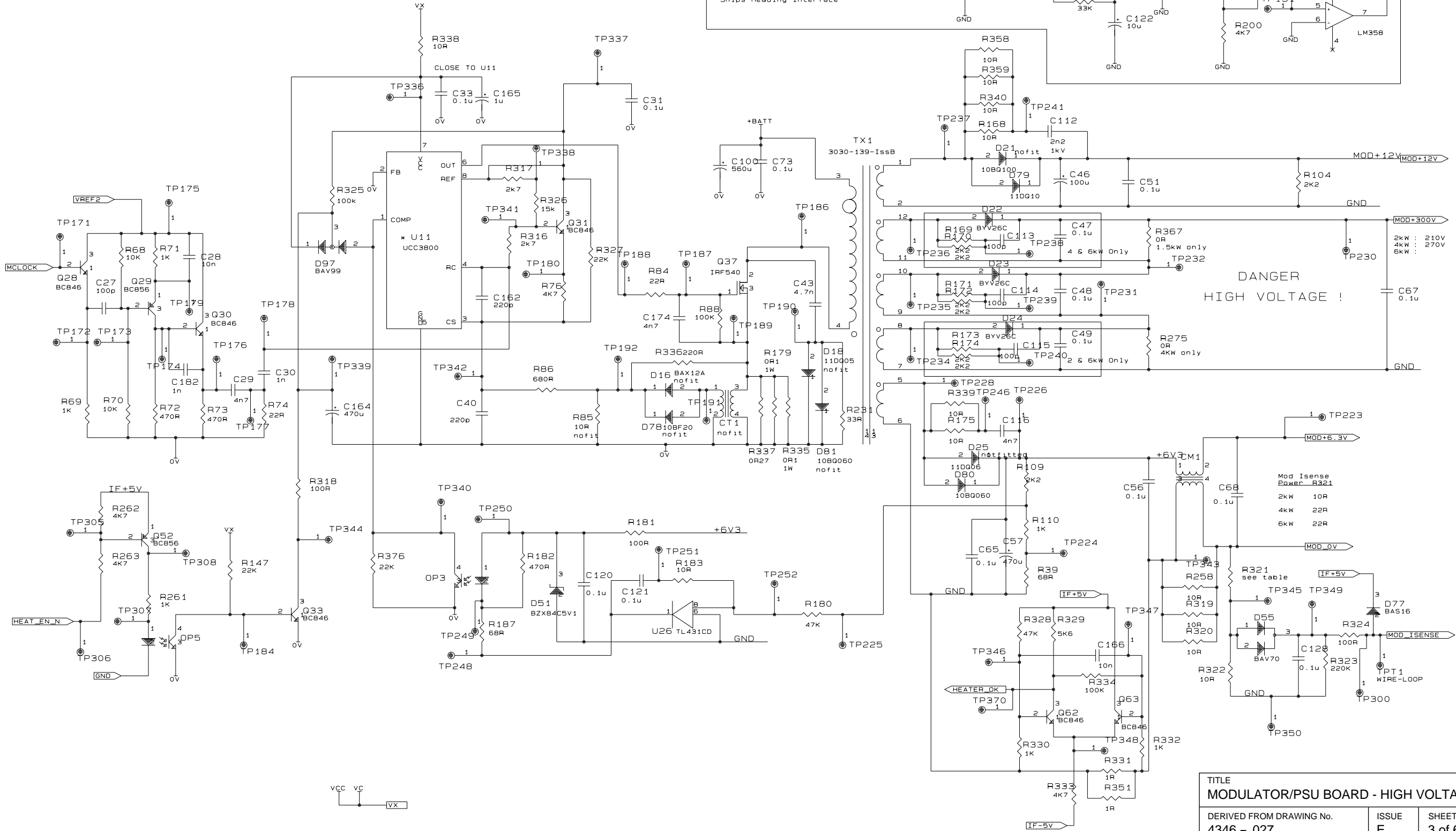
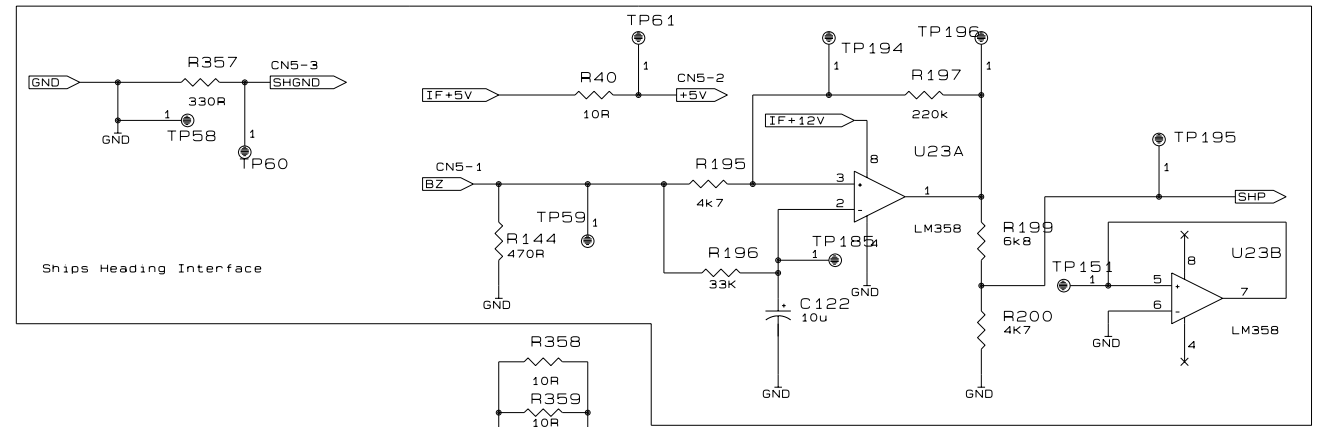

|   |            |                 |
|---|------------|-----------------|
| TITLE<br>MODULATOR/PSU BOARD - HIGH VOLTAGE PSU |            |                 |
| DERIVED FROM DRAWING No.<br>4346 - 027          | ISSUE<br>E | SHEET<br>3 of 6 |

Part 2  
Chapter 6

Modulator/PSU Board - Modulator

Part 2  
Chapter 6

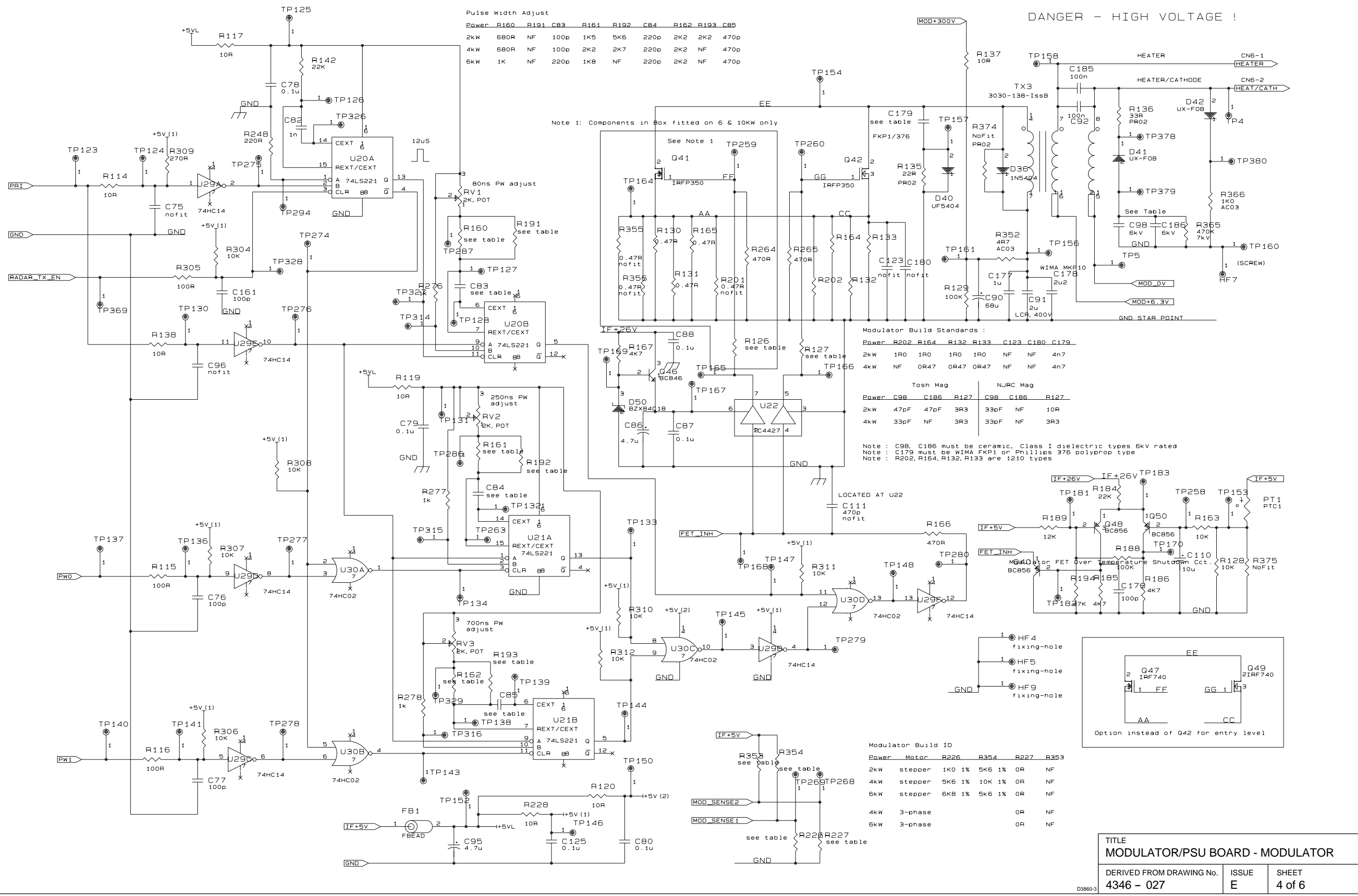

TITLE  
**MODULATOR/PSU BOARD - MODULATOR**

DERIVED FROM DRAWING No. 4346 - 027

ISSUE E

SHEET 4 of 6

Modulator/PSU Board - 3 Phase DC brushless motor drive

Not applicable to  
Radome Scanner Radars

|  |       |        |
|--|-------|--------|
| TITLE  |       |        |
| MODULATOR/PSU BOARD - 3 PHASE DC BRUSHLESS MOTOR DRIVE |       |        |
| DERIVED FROM DRAWING No.                               | ISSUE | SHEET  |
| 4346 - 027   | E     | 5 of 6 |

D3909-3

Modulator/PSU Board – Stepper Motor Drive

Part 2  
Chapter 6

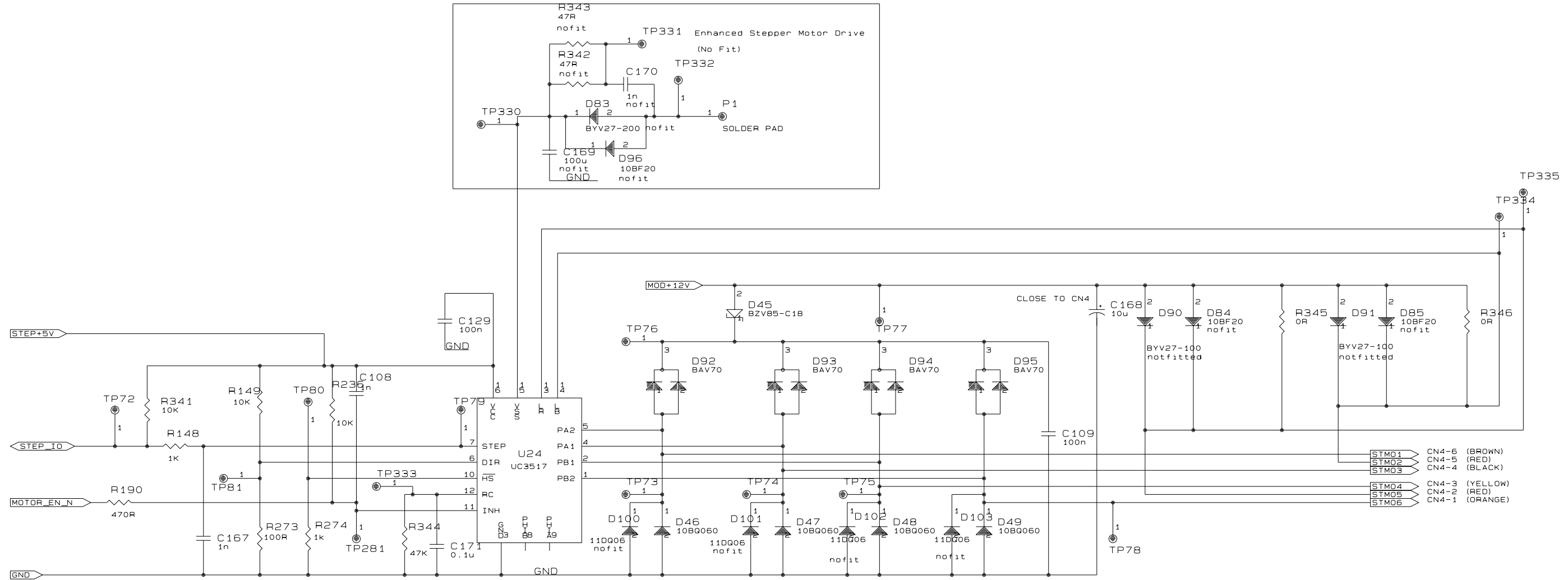

This circuit fitted for  
stepper motor based system only

|  |            |                 |
|--|------------|-----------------|
| TITLE<br>MODULATOR/PSU BOARD – STEPPER MOTOR DRIVE |            |                 |
| DERIVED FROM DRAWING No.<br>4346 – 027             | ISSUE<br>E | SHEET<br>6 of 6 |

Modulator/PSU Board – PCB layout (2kW, stepper motor)

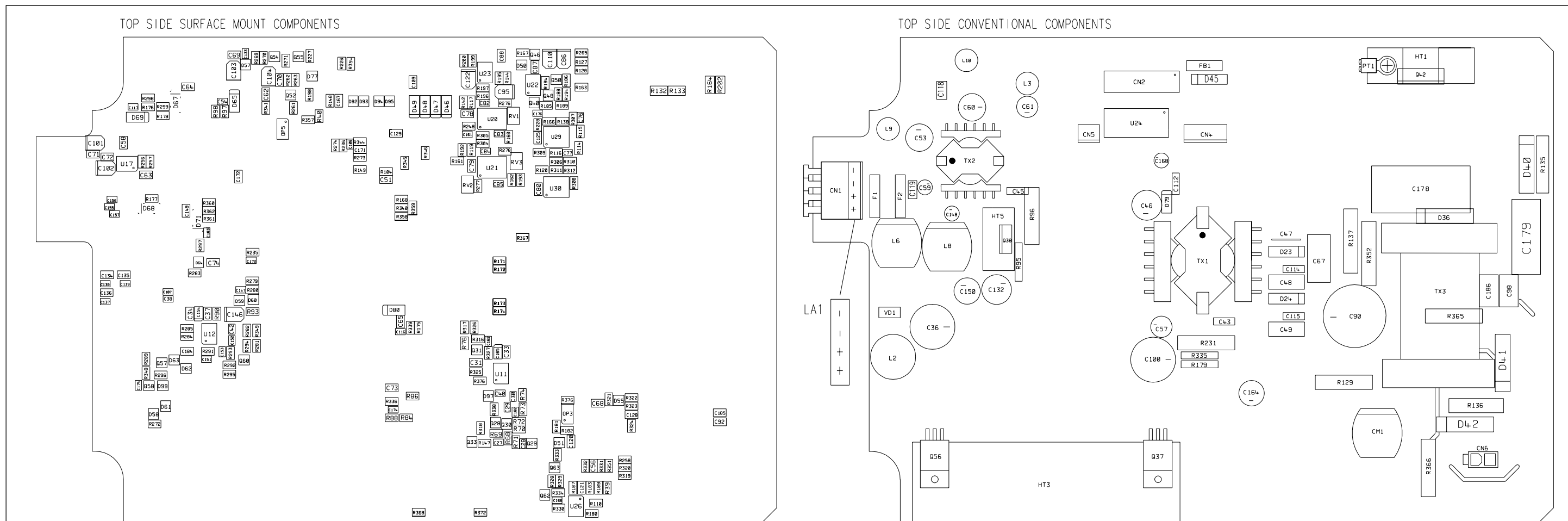

TOP SIDE SURFACE MOUNT COMPONENTS

| QTY | DESCRIPTION   | REF                         | QTY  | DESCRIPTION                          | REF  |
|-----|---|-----------------------------|--|--------------------------------------|--|
| 1   | P.C.B DETAIL  |                             | 3  | RESISTOR 1206 270R 1% 0.125W         | R309   |
| 1   | RESISTOR 1206 1K5 5% 0.125W                             | R161                        | 3  | RESISTOR VARIABLE 2K                 | RV1-3  |
| 2   | RESISTOR 1206 1R0 5% 0.125W                             | R331,351                    | 6  | CAPACITOR COG 0805 100pF 10% 50V     | C27,76,77,83,161,176                                     |
| 21  | RESISTOR 1206 10R 1% 0.125W                             | R40,114,117,119,120,        | 4  | CAPACITOR COG 0805 220pF 10% 50V     | C40,84,153,162   |
|     | 138,168,175,183,228,258,297,319,320-322,338-340,358,359 |                             | 1  | CAPACITOR COG 0805 470pF 10% 50V     | C85  |
| 3   | RESISTOR 1206 22R 5% 0.125W                             | R74,84,177                  | 15   | CAPACITOR X7R 0805 1000pF 10% 50V    | C30,38,42,82,108,133,137,138,139,152,155,156,167,182,187 |
| 10  | RESISTOR 1206 47R 5% 0.125W                             | R90,97,98,176,178,          | 4  | CAPACITOR X7R 0805 2.2nF 10% 50V     | C54,117,173,183  |
|     | 298,299,360-362   |                             | 3  | CAPACITOR X7R 0805 4.7nF 10% 50V     | C29,116,174  |
| 2   | RESISTOR 1206 68R 5% 0.125W                             | R39,187                     | 5  | CAPACITOR X7R 0805 10nF 10% 50V      | C28,147,151,157,166                                      |
| 9   | RESISTOR 1206 100R 1% 0.125W                            | R115,116,181,273,279,       | 1  | CAPACITOR X7R 0805 33nF 10% 50V      | C175   |
|     | 280,305,318,324   |                             | 38   | CAPACITOR X7R 1206 100nF 20% 50V     | C31,33,34,37,51,56,58,                                   |
| 2   | RESISTOR 1206 220R 5% 0.125W                            | R248,336                    | 62-65,68-74,78-80,87,88,92,109,120,121,125,128,129,134-136,149,171,172,184,185 |                                      |  |
| 8   | RESISTOR 1206 330R 5% 0.125W                            | R357                        | 2  | CAPACITOR TANTA 1uF 10% 16V          | C154,165   |
|     |   |                             | 3  | CAPACITOR ELEC 4.7uF 20% 25V         | C86,95,146   |
|     |   |                             | 5  | CAPACITOR ECE-V1CA100SR 10uF 20% 16V | C101,103,104,110,122                                     |
| 1   | RESISTOR 1206 510R 1% 0.125W                            | R256                        | 1  | CAPACITOR AL ELEC 1uF 20% 50V        | C102   |
| 4   | RESISTOR 1206 680R 5% 0.125W                            | R86,160,368,372             | 1  | DIODE ZENER SOT23 BZX84C15           | D99  |
| 16  | RESISTOR 1206 1K 1% 0.125W                              | R69,71,93,110,148,          | 5  | DIODE SOT23 BAS16                    | D57,61-63,77   |
|     | 226,261,274,276-278,289,296,330,332,348                 |                             | 8  | DIODE SOT23 BAV70                    | D55,59,60,64,92-95                                       |
| 4   | RESISTOR 1210 1R0 5% 0.5W                               | R132,133,164,202            | 1  | DIODE SOT23 BAV99                    | D97  |
| 8   | RESISTOR 1206 2K2 5% 0.125W                             | R104,109,162,171-174,193    | 1  | DIODE ZENER SOT23 BZX84C12           | D58  |
| 3   | RESISTOR 1206 2K7 5% 0.125W                             | R293,316,317                | 1  | DIODE ZENER SOT23 BZX84C18           | D50  |
| 1   | RESISTOR 1206 3K3 5% 0.125W                             | R285                        | 1  | DIODE ZENER SOT23 BZX84C5V1          | D51  |
| 1   | RESISTOR 1206 3K9 5% 0.125W                             | R282                        | 7  | DIODE SMB 10BQ60TR                   | D46-49,65,69,80  |
| 10  | RESISTOR 1206 4K7 5% 0.125W                             | R76,167,185,186,195,200,    | 0  | DIODE SMB 10BF20                     | (D67,68,71)  |
|     | 262,263,270,333   |                             | 11   | TRANSISTOR SOT23 BC846               | Q28,30,31,33,46,54,55,58,60,62,63                        |
| 3   | RESISTOR 1206 5K6 1% 0.125W                             | R192,329,354                | 6  | TRANSISTOR SOT23 BC856               | Q29,40,48,50,52,57                                       |
| 1   | RESISTOR 1206 6K8 1% 0.125W                             | R199                        | 2  | IC LOW POWER PWM UCC3800 S08         | U11,12   |
| 21  | RESISTOR 1206 10K 1% 0.125W                             | R68,70,128,149,163,236,257, | 1  | IC ADJUSTABLE REGULATOR LM317 S08    | U17  |
|     | 269,271,281,292,295,304,306-308,310-312,341,349         |                             | 2  | IC MONOSTABLE 74LS221 S014           | U20,21   |
| 2   | RESISTOR 1206 12K 5% 0.125W                             | R189,294                    | 1  | IC DUAL MOSFET DRIVER MIC4427CM S08  | U22  |
| 1   | RESISTOR 1206 15K 5% 0.125W                             | R326                        | 1  | IC DUAL OPAMP LM358M S08             | U23  |
| 5   | RESISTOR 1206 22K 5% 0.125W                             | R142,147,327,184,376        | 1  | IC TL431CD S08                       | U26  |
| 2   | RESISTOR 1206 33K 1% 0.125W                             | R196,283                    | 1  | IC HEX INVERTER MM74HC14M S014       | U29  |
| 5   | RESISTOR 1206 47K 5% 0.125W                             | R180,194,272,328,344        | 1  | IC QUAD NOR GATE 74HC02 S014         | U30  |
| 6   | RESISTOR 1206 100K 5% 0.125W                            | R88,188,235,291,325,334     | 2  | IC OPTO ISOLATOR PC357               | OP3,5  |
| 2   | RESISTOR 1206 220K 5% 0.125W                            | R197,323                    |  |                                      |  |
| 3   | RESISTOR 1206 0R0 0.125W                                | R345,346,367                |  |                                      |  |

TOP SIDE CONVENTIONAL COMPONENTS

| QTY | DESCRIPTION   | REF           | QTY | DESCRIPTION                                       | REF     |
|-----|---|---------------|-----|---|---------|
| 3   | RESISTOR 0.1R 1W PRO1 SERIES                        | R95,179,335   | 1   | TRANSFORMER LOW VOLT SUPPLY                       | TX2     |
| 1   | RESISTOR WIREWOUND 4R7 2.5W +/-10%                  | R352          | 1   | TRANSFORMER MODULATOR PULSE (REV. C)              | TX3     |
| 1   | RESISTOR WIREWOUND 10R 2.5W +/-5%                   | R137          | 1   | CONNECTOR CLAMP 4WAY WAGO                         | CN1     |
| 1   | RESISTOR 470K 1W 20% 7kV                            | R365          | 1   | HEADER 18WAY MOLEX 'PICOFLEX'                     | CN2     |
| 3   | RESISTOR 33R 2W PRO2 SERIES                         | R96,136,231   | 1   | HEADER 6WAY MOLEX 'KK' VERTICLE 0.1" PITCH        | CN4     |
| 1   | RESISTOR 100K 2W PRO2                               | R129          | 1   | HEADER 3WAY MOLEX 'KK' VERTICLE 0.1" PITCH        | CN5     |
| 1   | RESISTOR 22R 2W PRO2                                | R135          | 1   | HEADER 2WAY MOLEX-MINI                            | CN6     |
| 1   | RESISTOR 1K 2.5W 5%                                 | R366          | 2   | INDUCTOR NR12-4/02                                | CM1,L6  |
| 2   | CAPACITOR CERAMIC DISC 100pF 1KV                    | C114,115      | 1   | THERMISTOR PTHM04BC222TS2                         | PT1     |
| 1   | CAPACITOR CERAMIC 220pF 100V 2.54mm PITCH           | C118          | 1   | SCREW PAD HEAD STAINLESS STEEL 4x1/2" P021        | SC1     |
| 1   | CAPACITOR X7R 0805 33nF 10% 50V                     | C119          | 1   | WASHER M3 SINGLE COIL                             | W1      |
| 1   | CAPACITOR RADIAL 4.7nF 400V 10mm PITCH              | C43           | 2   | SLEEVING SILICONE RUBBER 1mm DIA. BLK 2x25mm LONG | SL1,2   |
| 1   | CAPACITOR POLYPROPYLENE RADIAL 4.7nF 2kV            | C179          | 1   | WIRE LINK   | C47,WL1 |
| 2   | CAPACITOR CERAMIC DISC 2.2nF 1KV                    | C45,112       | 1   | WIRE LOOP   | TPT1    |
| 2   | CAPACITOR POLYESTER 100nF 250V +/-10%               | C48,49        | 1   | SIL PAD 19x25                                     |         |
| 1   | CAPACITOR POLYESTER 100nF 400V +/-10%               | C67           | 1   | HEATSINK FET                                      | HT3     |
| 1   | CAPACITOR MKP10 1uF 400V                            | C177          | 1   | HEATSINK SW25-4                                   | HT1     |
| 3   | CAPACITOR ELECTROLYTIC 10uF 60V +80-20%             | C59,148,168   | 1   | HEATSINK REDPOINT PTF750                          | HT4     |
| 1   | CAPACITOR ELECTROLYTIC 68uF 400V +/-20%             | C90           | 1   | HEATSINK RETAINER CLIP 5901                       | HC1     |
| 4   | CAPACITOR ELECTROLYTIC 100uF 35V                    | C46,53,60,132 | 1   | VARIATOR METAL OXIDE V39ZA1                       | VD1     |
| 1   | CAPACITOR ELECTROLYTIC 220uF 25V +/-20% 3.5mm PITCH | C150          | -   | VARNISH ANTI TAMPER RED                           |         |
| 3   | CAPACITOR ELECTROLYTIC 470uF 10V +/-20%             | C57,61,164    | 2   | FIBRE SCREW SEAL                                  |         |
| 2   | CAPACITOR ELECTROLYTIC 560uF 35V +/-10%             | C36,100       | 2   | RIVSCREW  |         |
| 1   | DIODE RECTIFIER 11DQ10 100V 1.1A                    | D79           | 1   | LABEL POWER CONNECTOR                             | LA1     |
| 2   | DIODE BYV26C  | D23,24        |     |   |         |
| 1   | DIODE UF5404  | D40           |     |   |         |
| 1   | DIODE POWER 1N5404                                  | D36           |     |   |         |
| 1   | DIODE ZENER BZVC18                                  | D45           |     |   |         |
| 2   | DIODE HIGH VOLTAGE SANKEN UX-F0B                    | D41,42        |     |   |         |
| 3   | DIODE BYV27-200                                     | D29,30,70     |     |   |         |
| 2   | TRANSISTOR POWER 'ISOLATED' MOSFET IRF1540N         | Q37,38        |     |   |         |
| 1   | TRANSISTOR POWER MOSFET 'HEXFET' IRFP350            | Q42           |     |   |         |
| 1   | TRANSISTOR ISOWATT MOSFET STP6N05F1                 | Q56           |     |   |         |
| 1   | IC STEPPER MOTOR DRIVE UC3517N DIL16                | U24           |     |   |         |
| 1   | CHOKE 10uH 10A                                      | L2            |     |   |         |
| 3   | CHOKE 100uH 5mm PITCH                               | L3,9,10       |     |   |         |
| 3   | INDUCTOR FERRITE BEAD BL01RN1A62                    | FB1,F1,2      |     |   |         |
| 1   | TRANSFORMER T300V (REV. B)                          | TX1           |     |   |         |

2ND STAGE ASSEMBLY (NOTE 10.) OPTION 1 : TOSHIBA MAGNETRON

| QTY | DESCRIPTION                               | REF       |
|-----|---|-----------|
| 1   | RESISTOR 1206 3R3 5% 0.125W (HAND FIT)    | R127      |
| 2   | CAPACITOR RADIAL 47pF 6KV                 | C98,186   |
| 1   | TOSHIBA LABEL TO REVERSE OF PCB UNDER TX1 |           |
|     | OPTION 2 : NJRC MAGNETRON                 |           |
| 1   | RESISTOR 1206 10R 1% 0.125W (HAND FIT)    | R127      |
| 1   | CAPACITOR RADIAL 33pF 6KV                 | C98,(186) |
| 1   | NJRC LABEL TO REVERSE OF PCB UNDER TX1    |           |

|   |            |                 |
|---|------------|-----------------|
| TITLE<br>MODULATOR/PSU BOARD -<br>PCB LAYOUT (2kW, STEPPER MOTOR) |            |                 |
| DERIVED FROM DRAWING No.<br>4346 - 017                            | ISSUE<br>V | SHEET<br>1 of 1 |

D4098-3

Modulator/PSU Board – PCB layout (4kW, stepper motor)

Part 2  
Chapter 6

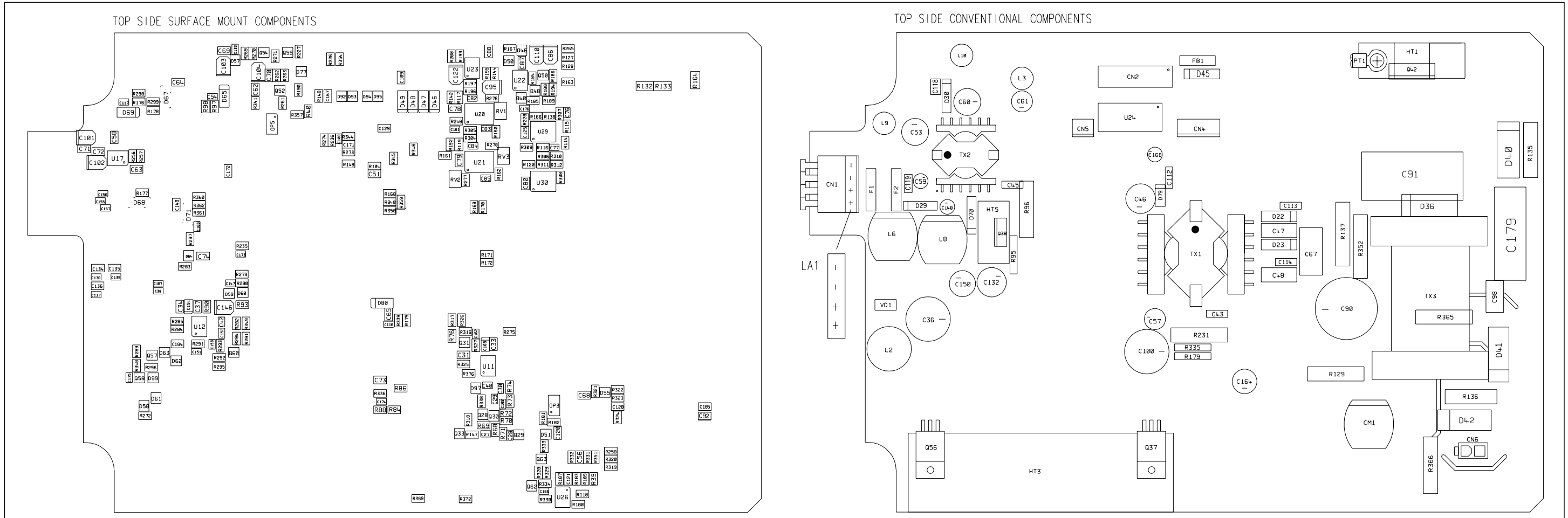

TOP SIDE SURFACE MOUNT COMPONENTS

|    |   |  |  |  |  |
|----|---|--|--|--|--|
| 1  | P.C.B DETAIL  |  |  |  |  |
| 3  | RESISTOR 1210 0.47R ±0.125W                         | R132,133,164   |  |  | R309   |
| 2  | RESISTOR 1206 1R0 5% 0.125W                         | R331,351   |  |  | RV1-3  |
| 20 | RESISTOR 1206 10R 1% 0.125W                         | R40,114,117,119,120,138,168,175,183,228,258,297,319,320,322,338-340,358,359    |  |  | C40,84,153,162   |
| 4  | RESISTOR 1206 22R 5% 0.125W                         | R74,84,177,321   |  |  | C85  |
| 10 | RESISTOR 1206 47R 5% 0.125W                         | R90,97,98,176,178,298,299,360-362  |  |  | C30,38,42,82,108,133,137,138,139,152,155,156,167,182,187   |
| 2  | RESISTOR 1206 68R 5% 0.125W                         | R39,187  |  |  | C54,117,173,183  |
| 9  | RESISTOR 1206 100R 1% 0.125W                        | R115,116,181,273,279,280,305,318,324   |  |  | C29,116,174  |
| 1  | RESISTOR 1206 330R 5% 0.125W                        | R357   |  |  | C28,147,151,157,166  |
| 2  | RESISTOR 1206 220R 5% 0.125W                        | R248,336   |  |  | C175   |
| 8  | RESISTOR 1206 470R 5% 0.125W                        | R72,73,144,166,182,190,265,284   |  |  | C31,33,34,37,51,56,58,62-65,68-74,78-80,87,88,92,109,120,121,125,128,129,134-136,149,171,172,184,185 |
| 1  | RESISTOR 1206 510R 1% 0.125W                        | R256   |  |  | C154,165   |
| 3  | RESISTOR 1206 680R 5% 0.125W                        | R86,160,372  |  |  | C86,95,146   |
| 16 | RESISTOR 1206 1K 1% 0.125W                          | R69,71,93,110,148,261,274,276-278,289,296,330,332,348,369                      |  |  | C101,103,104,110,122   |
| 8  | RESISTOR 1206 2K2 5% 0.125W                         | R104,109,161,162,169-172   |  |  | -  |
| 4  | RESISTOR 1206 2K7 5% 0.125W                         | R192,293,316,317   |  |  | C102   |
| 1  | RESISTOR 1206 3K3 5% 0.125W                         | R285   |  |  | D57,61-63,77   |
| 1  | RESISTOR 1206 3K9 5% 0.125W                         | R282   |  |  | D55,59,60,64,92-95   |
| 10 | RESISTOR 1206 4K7 5% 0.125W                         | R76,167,185,186,195,200,262,263,270,333  |  |  | D97  |
| 2  | RESISTOR 1206 5K6 1% 0.125W                         | R226,329   |  |  | D99  |
| 1  | RESISTOR 1206 6K8 1% 0.125W                         | R199   |  |  | D50  |
| 22 | RESISTOR 1206 10K 1% 0.125W                         | R68,70,128,149,163,236,257,269,271,281,292,295,304,306-308,310-312,341,349,354 |  |  | D51  |
| 2  | RESISTOR 1206 12K 5% 0.125W                         | R189,294   |  |  | D46-49,65,69,80  |
| 1  | RESISTOR 1206 15K 5% 0.125W                         | R326   |  |  | (D67,68,71)  |
| 5  | RESISTOR 1206 22K 5% 0.125W                         | R142,147,184,327,376   |  |  | Q28,30,31,33,46,54,55,58,60,62,63  |
| 2  | RESISTOR 1206 33K 1% 0.125W                         | R196,283   |  |  | Q29,40,48,50,52,57   |
| 5  | RESISTOR 1206 47K 5% 0.125W                         | R180,194,272,328,344   |  |  | U11,12   |
| 6  | RESISTOR 1206 100K 5% 0.125W                        | R88,188,235,291,325,334  |  |  | U17  |
| 2  | RESISTOR 1206 220K 5% 0.125W                        | R197,323   |  |  | U20,21   |
| 3  | RESISTOR 1206 0R0 0.125W                            | R275,345,346   |  |  | U22  |
| 1  | RESISTOR 1206 3R3 5% 0.125W                         | R127   |  |  | U23  |
| 1  | RESISTOR 1206 270R 1% 0.125W                        | R309   |  |  | U26  |
| 3  | RESISTOR WIREWOUND 4R7 2.5W +/-10%                  | R352   |  |  | U29  |
| 1  | RESISTOR WIREWOUND 10R 2.5W +/-5%                   | R137   |  |  | U30  |
| 1  | RESISTOR 100K 2W PRO2                               | R129   |  |  |  |
| 3  | RESISTOR 33R 2W PRO2 SERIES                         | R96,136,231  |  |  |  |
| 1  | RESISTOR 22R 2W PRO2                                | R135   |  |  |  |
| 1  | RESISTOR 470K 1W 20% 7kV                            | R365   |  |  |  |
| 1  | RESISTOR 1K 2.5W 5%                                 | R366   |  |  |  |
| 2  | CAPACITOR CERAMIC DISC 2.2nF 1KV                    | C45,112  |  |  |  |
| 1  | CAPACITOR RADIAL 33pF 6KV 10mm PITCH                | C98  |  |  |  |
| 2  | CAPACITOR CERAMIC DISC 100pF 1KV                    | C113,114   |  |  |  |
| 1  | CAPACITOR CERAMIC 220pF 100V 2.54mm PITCH           | C118   |  |  |  |
| 1  | CAPACITOR CERAMIC 1nF 1KV +/-10%                    | C119   |  |  |  |
| 1  | CAPACITOR RADIAL 4.7nF 400V 10mm PITCH              | C43  |  |  |  |
| 1  | CAPACITOR POLYPROPYLENE RADIAL 4.7nF 2kV            | C179   |  |  |  |
| 2  | CAPACITOR POLYESTER 100nF 250V +/-10%               | C47,48   |  |  |  |
| 1  | CAPACITOR POLYESTER 100nF 400V +/-10%               | C67  |  |  |  |
| 1  | CAPACITOR MKP10 2.2uF 400V                          | C178   |  |  |  |
| 3  | CAPACITOR ELECTROLYTIC 10uF 60V +/-20%              | C59,148,168  |  |  |  |
| 1  | CAPACITOR ELECTROLYTIC 68uF 400V +/-20%             | C90  |  |  |  |
| 4  | CAPACITOR ELECTROLYTIC 100uF 35V                    | C46,53,60,132  |  |  |  |
| 1  | CAPACITOR ELECTROLYTIC 220uF 25V +/-20% 3.5mm PITCH | C150   |  |  |  |
| 3  | CAPACITOR ELECTROLYTIC 470uF 10V +/-20%             | C57,61,164   |  |  |  |
| 2  | CAPACITOR ELECTROLYTIC 560uF 35V +/-10%             | C36,100  |  |  |  |
| 1  | DIODE RECTIFIER 11D010 100V 1.1A                    | D79  |  |  |  |
| 2  | DIODE BYV26C  | D22,23   |  |  |  |
| 1  | DIODE UF5404  | D40  |  |  |  |
| 1  | DIODE POWER 1N5404                                  | D36  |  |  |  |
| 1  | DIODE ZENER BZVCL18                                 | D45  |  |  |  |
| 2  | DIODE HIGH VOLTAGE SANKENUX-F0B                     | D41,42   |  |  |  |
| 3  | DIODE BYV27-200                                     | D29,30,70  |  |  |  |
| 2  | TRANSISTOR POWER 'ISOLATED' MOSFET IRF1540N         | Q37,38   |  |  |  |
| 1  | TRANSISTOR POWER MOSFET 'HEXFET' IRFP350            | Q42  |  |  |  |
| 1  | TRANSISTOR ISOWATT MOSFET STP6N05F1                 | Q56  |  |  |  |
| 1  | IC STEPPER MOTOR DRIVE UC3517N DIL16                | U24  |  |  |  |
| 3  | RESISTOR 0.1R 1W PRO1 SERIES                        | R95,179,335  |  |  |  |
| 1  | TRANSISTOR POWER MOSFET 'HEXFET' IRFP350            | Q42  |  |  |  |
| 1  | TRANSISTOR ISOWATT MOSFET STP6N05F1                 | Q56  |  |  |  |
| 1  | IC STEPPER MOTOR DRIVE UC3517N DIL16                | U24  |  |  |  |
| 3  | RESISTOR 33R 2W PRO2 SERIES                         | R96,136,231  |  |  |  |
| 1  | CHOKE 10uH 10A                                      | L2   |  |  |  |
| 1  | RESISTOR 22R 2W PRO2                                | R135   |  |  |  |
| 3  | CHOKE 100uH 5mm PITCH                               | L3,9,10  |  |  |  |
| 1  | INDUCTOR FERRITE BEAD BLO1RN1A62                    | FB1,F1,2   |  |  |  |
| 1  | TRANSFORMER T300V (REV. B)                          | TX1  |  |  |  |
| 2  | TRANSFORMER LOW VOLT SUPPLY                         | TX2  |  |  |  |
| 1  | TRANSFORMER MODULATOR PULSE (REV. C)                | TX3  |  |  |  |
| 1  | CONNECTOR CLAMP 4WAY WAGO                           | CN1  |  |  |  |
| 1  | HEADER 18WAY MOLEX 'PICOFLEX'                       | CN2  |  |  |  |
| 1  | HEADER 6WAY MOLEX 'KK' VERTICLE 0.1" PITCH          | CN4  |  |  |  |
| 1  | HEADER 3WAY MOLEX 'KK' VERTICLE 0.1" PITCH          | CN5  |  |  |  |
| 1  | HEADER 2WAY MOLEX-MINI                              | CN6  |  |  |  |
| 2  | INDUCTOR RN112-4/02                                 | CM1,L6   |  |  |  |
| 1  | THERMISTOR PTH9M04BC222TS2                          | PT1  |  |  |  |
| 1  | SCREW PAN HEAD STAINLESS STEEL 4x1/2" P021          | SC1  |  |  |  |
| 1  | WASHER M3 SINGLE COIL                               | W1   |  |  |  |
| 1  | SLEEVE SILICONE RUBBER 1mm DIA. BLK 2x25mm LONG     | SL1,2  |  |  |  |
| 1  | WIRE LINK   | WL1  |  |  |  |
| 1  | WIRE LOOP   | TPT1   |  |  |  |
| 1  | SIL PAD 19x25                                       |  |  |  |  |
| 1  | HEATSINK FET  | HT3  |  |  |  |
| 1  | HEATSINK SW25-4                                     | HT1  |  |  |  |
| 1  | HEATSINK REDPOINT PTF750                            | HT4  |  |  |  |
| 1  | HEATSINK RETAINER CLIP 5901                         | HC1  |  |  |  |
| 1  | VARIABLE RESISTOR METAL OXIDE V39ZA1                | VD1  |  |  |  |
| 2  | FIBRE SCREW SEAL                                    |  |  |  |  |
| 2  | RIVSCREW  |  |  |  |  |
| 1  | LABEL POWER CONNECTOR                               | LA1  |  |  |  |

TOP SIDE CONVENTIONAL COMPONENTS

|   |   |               |   |   |          |
|---|---|---------------|---|---|----------|
| 3 | RESISTOR 0.1R 1W PRO1 SERIES                        | R95,179,335   | 2 | TRANSISTOR POWER 'ISOLATED' MOSFET IRF1540N     | Q37,38   |
| 1 | RESISTOR WIREWOUND 4R7 2.5W +/-10%                  | R352          | 1 | TRANSISTOR POWER MOSFET 'HEXFET' IRFP350        | Q42      |
| 1 | RESISTOR WIREWOUND 10R 2.5W +/-5%                   | R137          | 1 | TRANSISTOR ISOWATT MOSFET STP6N05F1             | Q56      |
| 1 | RESISTOR 100K 2W PRO2                               | R129          | 1 | IC STEPPER MOTOR DRIVE UC3517N DIL16            | U24      |
| 3 | RESISTOR 33R 2W PRO2 SERIES                         | R96,136,231   | 1 | CHOKE 10uH 10A                                  | L2       |
| 1 | RESISTOR 22R 2W PRO2                                | R135          | 3 | CHOKE 100uH 5mm PITCH                           | L3,9,10  |
| 1 | RESISTOR 470K 1W 20% 7kV                            | R365          | 3 | INDUCTOR FERRITE BEAD BLO1RN1A62                | FB1,F1,2 |
| 1 | RESISTOR 1K 2.5W 5%                                 | R366          | 1 | TRANSFORMER T300V (REV. B)                      | TX1      |
| 2 | CAPACITOR CERAMIC DISC 2.2nF 1KV                    | C45,112       | 1 | TRANSFORMER LOW VOLT SUPPLY                     | TX2      |
| 1 | CAPACITOR RADIAL 33pF 6KV 10mm PITCH                | C98           | 1 | TRANSFORMER MODULATOR PULSE (REV. C)            | TX3      |
| 2 | CAPACITOR CERAMIC DISC 100pF 1KV                    | C113,114      | 1 | CONNECTOR CLAMP 4WAY WAGO                       | CN1      |
| 1 | CAPACITOR CERAMIC 220pF 100V 2.54mm PITCH           | C118          | 1 | HEADER 18WAY MOLEX 'PICOFLEX'                   | CN2      |
| 1 | CAPACITOR CERAMIC 1nF 1KV +/-10%                    | C119          | 1 | HEADER 6WAY MOLEX 'KK' VERTICLE 0.1" PITCH      | CN4      |
| 1 | CAPACITOR RADIAL 4.7nF 400V 10mm PITCH              | C43           | 1 | HEADER 3WAY MOLEX 'KK' VERTICLE 0.1" PITCH      | CN5      |
| 1 | CAPACITOR POLYPROPYLENE RADIAL 4.7nF 2kV            | C179          | 1 | HEADER 2WAY MOLEX-MINI                          | CN6      |
| 2 | CAPACITOR POLYESTER 100nF 250V +/-10%               | C47,48        | 2 | INDUCTOR RN112-4/02                             | CM1,L6   |
| 1 | CAPACITOR POLYESTER 100nF 400V +/-10%               | C67           | 1 | THERMISTOR PTH9M04BC222TS2                      | PT1      |
| 1 | CAPACITOR MKP10 2.2uF 400V                          | C178          | 1 | SCREW PAN HEAD STAINLESS STEEL 4x1/2" P021      | SC1      |
| 3 | CAPACITOR ELECTROLYTIC 10uF 60V +/-20%              | C59,148,168   | 1 | WASHER M3 SINGLE COIL                           | W1       |
| 1 | CAPACITOR ELECTROLYTIC 68uF 400V +/-20%             | C90           | 1 | SLEEVE SILICONE RUBBER 1mm DIA. BLK 2x25mm LONG | SL1,2    |
| 4 | CAPACITOR ELECTROLYTIC 100uF 35V                    | C46,53,60,132 | 1 | WIRE LINK                                       | WL1      |
| 1 | CAPACITOR ELECTROLYTIC 220uF 25V +/-20% 3.5mm PITCH | C150          | 1 | WIRE LOOP                                       | TPT1     |
| 3 | CAPACITOR ELECTROLYTIC 470uF 10V +/-20%             | C57,61,164    | 1 | SIL PAD 19x25                                   |          |
| 2 | CAPACITOR ELECTROLYTIC 560uF 35V +/-10%             | C36,100       | 1 | HEATSINK FET                                    | HT3      |
| 1 | DIODE RECTIFIER 11D010 100V 1.1A                    | D79           | 1 | HEATSINK SW25-4                                 | HT1      |
| 2 | DIODE BYV26C  | D22,23        | 1 | HEATSINK REDPOINT PTF750                        | HT4      |
| 1 | DIODE UF5404  | D40           | 1 | HEATSINK RETAINER CLIP 5901                     | HC1      |
| 1 | DIODE POWER 1N5404                                  | D36           | 1 | VARIABLE RESISTOR METAL OXIDE V39ZA1            | VD1      |
| 1 | DIODE ZENER BZVCL18                                 | D45           | 2 | FIBRE SCREW SEAL                                |          |
| 2 | DIODE HIGH VOLTAGE SANKENUX-F0B                     | D41,42        | 2 | RIVSCREW  |          |
| 3 | DIODE BYV27-200                                     | D29,30,70     | 1 | LABEL POWER CONNECTOR                           | LA1      |

|   |            |                 |
|---|------------|-----------------|
| TITLE<br>MODULATOR/PSU BOARD -<br>PCB LAYOUT (4kW, STEPPER MOTOR) |            |                 |
| DERIVED FROM DRAWING No.<br>4346 - 005                            | ISSUE<br>S | SHEET<br>1 of 2 |

IF Receiver - Top level

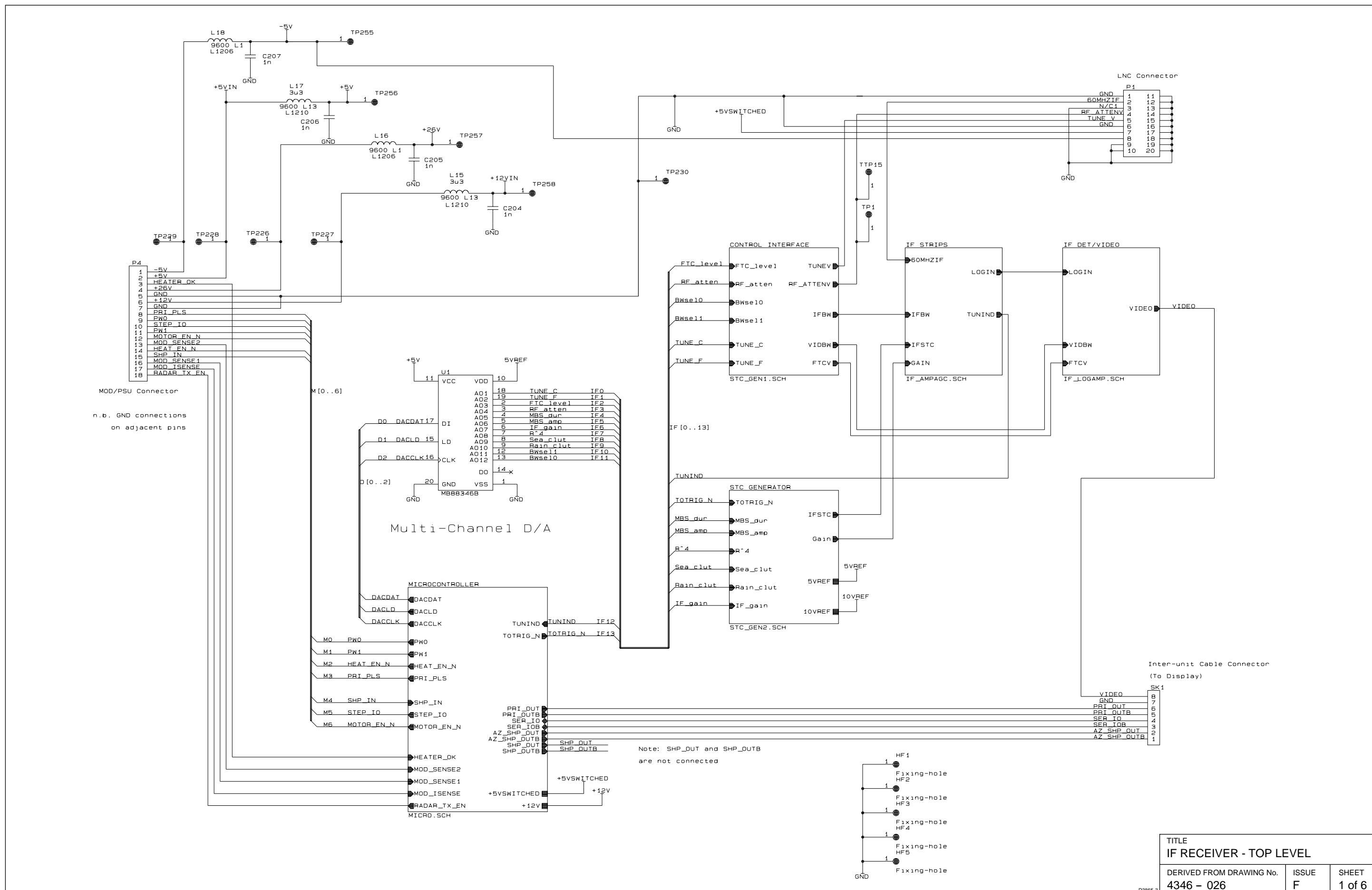

Part 2  
Chapter 6

|  |            |                 |
|--|------------|-----------------|
| TITLE<br>IF RECEIVER - TOP LEVEL       |            |                 |
| DERIVED FROM DRAWING No.<br>4346 - 026 | ISSUE<br>F | SHEET<br>1 of 6 |

D3865-3

IF Receiver - PCB Layout

Part 2  
Chapter 6

| TOP SIDE SURFACE MOUNT COMPONENTS |  |   |
|-----------------------------------|--|---|
| 1                                 | P.C.B DETAIL                                     | 3015-129  |
| 1                                 | RESISTOR 1206 27K 1% 0.125W                      | R146  |
| 23                                | RESISTOR 1206 1K 1% 0.125W                       | R1-4, 13, 20, 33, 34, 63, 64, 87, 101, 104, 113-115, 122, 134, 142, 143, 145, 202, 322  |
| 1                                 | RESISTOR 1206 68K 1% 0.125W                      | R49   |
| 1                                 | RESISTOR 1206 5K6 1% 0.125W                      | R212  |
| 3                                 | RESISTOR 1206 10R 1% 0.125W                      | R210, 332, 338  |
| 2                                 | RESISTOR 1206 33K 1% 0.125W                      | R162, 331   |
| 7                                 | RESISTOR 1206 560R 1% 0.125W                     | R24, 59, 105, 125, 201, 218, 310  |
| 1                                 | RESISTOR 1206 6K8 1% 0.125W                      | R136  |
| 7                                 | RESISTOR 1206 100R 1% 0.125W                     | R79, 97, 103, 216, 319-321  |
| 4                                 | RESISTOR 1206 1K5 5% 0.125W                      | R9, 138, 220, 302   |
| 1                                 | RESISTOR 1206 ORO 0.125W                         | (R56-58, 62, 66, 67, ) (68, 69, 335), 337   |
| 1                                 | RESISTOR 1206 220K 5% 0.125W                     | R140  |
| 4                                 | RESISTOR 1206 22K 5% 0.125W                      | R123, 124, 213, 214   |
| 5                                 | RESISTOR 1206 4K7 5% 0.125W                      | R71, 78, 90, 309, 311   |
| 2                                 | RESISTOR 1206 68R 5% 0.125W                      | R23, 29   |
| 7                                 | RESISTOR 1206 2K2 5% 0.125W                      | R5, 15, 35, 52, 65, 139, 206  |
| 4                                 | RESISTOR 1206 100K 5% 0.125W                     | R19, 300, 324, 326  |
| 21                                | RESISTOR 1206 10K 1% 0.125W                      | R22, 32, 36, 41, 42, 44-48, 75, 137, 163, 209, 312, 314, 316-318, 327, 330  |
| 5                                 | RESISTOR 1206 15K 5% 0.125W                      | R91, 94, 98, 303, 306   |
| 5                                 | RESISTOR 1206 330R 5% 0.125W                     | R7, 30, 73, 144, 211  |
| 2                                 | RESISTOR 1206 180R 5% 0.125W                     | R17, 155  |
| 2                                 | RESISTOR 1206 220R 5% 0.125W                     | R31, 334  |
| 3                                 | RESISTOR 1206 330K 5% 0.125W                     | R37, 50, 119  |
| 8                                 | RESISTOR 1206 680R 5% 0.125W                     | R18, 89, 93, 106, 141, 217, 307, 308  |
| 8                                 | RESISTOR 1206 1K8 5% 0.125W                      | R11, 51, 53, 55, 60, 74, 96, 215  |
| 9                                 | RESISTOR 1206 470R 5% 0.125W                     | R6, 12, 26-28, 70, 72, 131, 203   |
| 1                                 | RESISTOR 1206 3K9 5% 0.125W                      | R100  |
| 1                                 | RESISTOR 1206 120R 5% 0.125W                     | R102  |
| 6                                 | RESISTOR 1206 22R 5% 0.125W                      | R111, 112, 116, 126, 127, 129   |
| 5                                 | RESISTOR 1206 47K 5% 0.125W                      | R128, 304, 305, 328, 329  |
| 0                                 | RESISTOR 1206 470K 5% 0.125W                     | (R161)  |
| 4                                 | RESISTOR 1206 390R 5% 0.25W                      | R25, 118, 130, 208  |
| 2                                 | RESISTOR 1206 47R 5% 0.125W                      | R14, 21   |
| 7                                 | RESISTOR 1206 3K3 1% 0.25W                       | R8, 10, 54, 76, 117, 315, 219   |
| 1                                 | RESISTOR 1206 2K7 5% 0.125W                      | R16   |
| 32                                | CAPACITOR X7R 0805 1000pF 10% 50V                | C4, 6, 13, 15, 17, 21, 22, 32, 47, 52, 71, 82, 87-89, 93, 103, 104, 123, 204-207, 209, 210, 211, 214, 215, 217, 218, 223, 228 |
| 1                                 | CAPACITOR COG 0805 1.5pF 5% 50V                  | C67   |
| -                                 | -  | -   |
| 2                                 | CAPACITOR COG 0805 12pF 5% 50V                   | C1, 90  |
| 15                                | CAPACITOR ECE-V1CA100SR 10uF 20% 16V             | C3, 9, 10, 18-20, 24, 46, 51, 81, 102, 110, 128, 212, 213   |
| 4                                 | CAPACITOR ECE-VOJA101SP 100uF 20% 6.3V           | C16, 111, 114, 225  |
| 17                                | CAPACITOR X7R 1206 100nF 20% 50V                 | C5, 7, 12, 29, 39, 73, 112, 113, 125, 129, 200-203, 224, 226, 227   |
| 6                                 | CAPACITOR X7R 0805 10nF 10% 50V                  | C25, 38, 42, 69, 75, 208  |
| 6                                 | CAPACITOR COG 0805 100pF 10% 50V                 | C23, 43, 85, 95, 219, 221   |
| 1                                 | CAPACITOR COG 0805 220pF 10% 50V                 | C44   |
| 11                                | CAPACITOR COG 0805 22pF 5% 50V                   | C45, 48, 50, 53, 55, 74, 80, 92, 94, 119, 120   |
| 3                                 | CAPACITOR COG 0805 27pF 5% 50V                   | C56, 65, 97   |
| 2                                 | CAPACITOR COG 0805 18pF 5% 50V                   | C2, 83  |
| 3                                 | CAPACITOR COG 0805 15pF 5% 50V                   | C63, 64, 220  |
| 2                                 | CAPACITOR COG 0805 470pF 10% 50V                 | C8, 40  |
| -                                 | -  | -   |
| 11                                | DIODE SOT23 BAS16                                | D1, 3, 5, 11, 12, 16, 18, 22, 26-28   |
| 1                                 | DIODE SOT23 BAV99                                | D19   |
| 1                                 | DIODE SOT23 HSMP-3830 T31                        | D17   |
| 2                                 | DIODE SOT23 BAV70                                | D7, 8   |
| 0                                 | DIODE ZENER SOT23 BZX84C12V                      | (D32)   |
| 1                                 | DIODE VARACTOR SOD123 BB512                      | D4  |
| 4                                 | DIODE MOSFET SOT23 BF999                         | Q31, 32, 34, 35   |
| 10                                | TRANSISTOR SOT23 BSR18A PNP                      | Q2, 8, 11, 12, 15, 16, 19, 23, 33, 38   |
| 16                                | TRANSISTOR SOT23 FMMT3904CTR-ND ZETEX            | Q1, 3-7, 9, 10, 13, 14, 18, 21, 22, 36, 37, 43  |
| 2                                 | TRANSISTOR POWER MOSFET 2SK2103                  | Q39, 41   |
| 2                                 | TRANSISTOR BC817                                 | Q40, 42   |
| 1                                 | IC DIGITAL/ANALOGUE CONVERTER 8-BIT 20PIN SSOP   | U1  |
| 4                                 | IC AMPLIFIER SL1613/C/MPTC S08                   | U2-5  |
| 5                                 | IC OPAMP QUAD TL084CD S014                       | U6-8, 11, 21  |
| 2                                 | IC AMPLIFIER IF MC1350D S08                      | U9, 10  |
| 1                                 | IC QUAD TRI-STATE DIFF. LINE DRIVER DS34C87 S016 | U12   |
| 1                                 | IC MICROPROCESSOR uPD78P054GC-389 FP80           | U13   |

BOTTOM SIDE CONVENTIONAL COMPONENTS

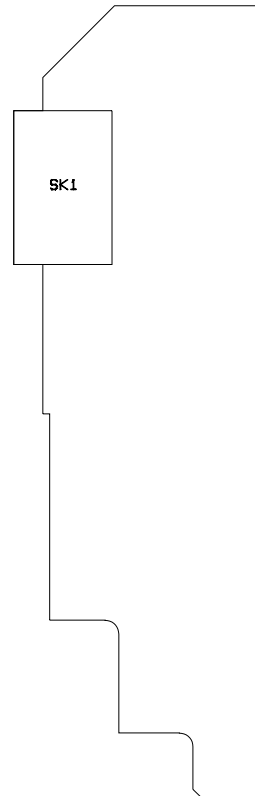

TOP SIDE SURFACE MOUNT COMPONENTS

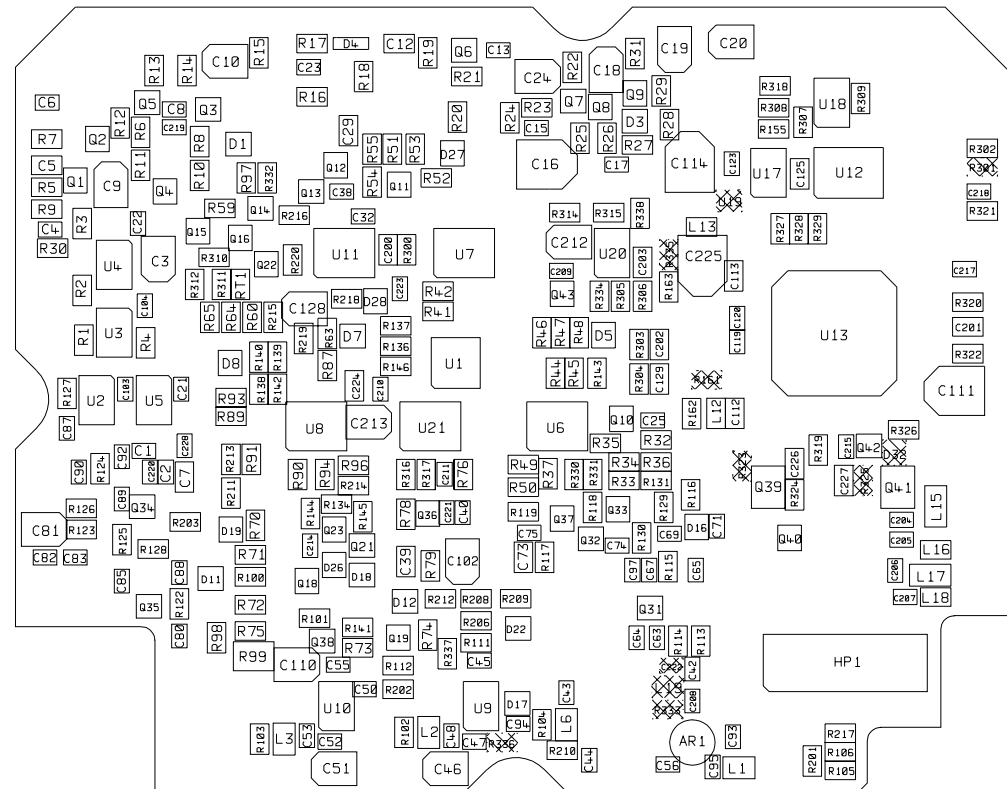

TOP SIDE CONVENTIONAL COMPONENTS

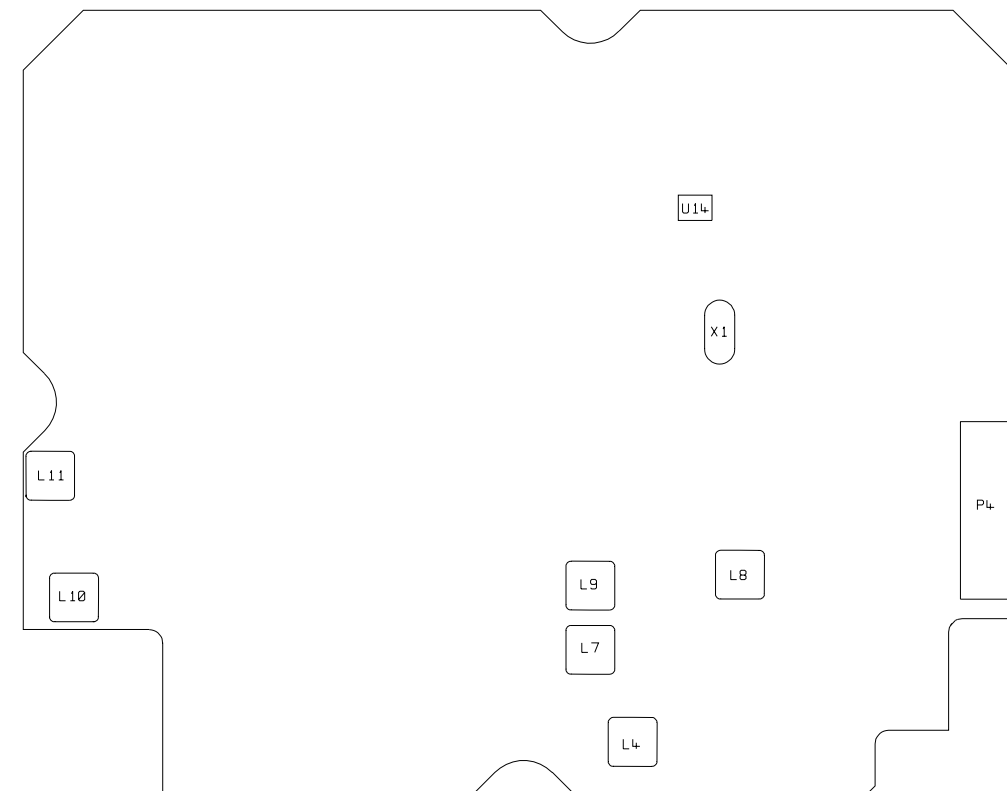

| TOP SIDE SURFACE MOUNT COMPONENTS (CONTINUED) |  |                 |
|---|--|-----------------|
| 1   | IC RS485/422 TRANSCEIVER DS75176 S08     | U17             |
| 1   | IC EEPROM ST24C01A S08                   | U18             |
| 0   | IC MAX823 SOT23-5                        | (U19)           |
| 1   | IC TL431CD S08                           | U20             |
| 2   | CHIP INDUCTOR 1210 10uH ELJ-FA100KF2     | L1, 6           |
| 2   | CHIP INDUCTOR 1210 220nH ELJ-FAR22MF2    | L2, 3           |
| 4   | SOLID CHIP INDUCTOR 1206 10uH BLM32A07   | L12, 13, 16, 18 |
| 2   | CHIP INDUCTOR 1210 3.3uH NLC322522T-3R3M | L15, 17         |
| 1   | TRANSISTOR BIPOLAR MSA-1105              | AR1             |
| 1   | CONNECTOR 20WAY CLH-110-F-D-DV-TR        | P1              |
| 2   | THERMISTOR 1206 2K5 10%                  | RT1             |
| 1   | RESISTOR TRIMMER 1K                      | R99             |

| TOP SIDE CONVENTIONAL COMPONENTS |                                |          |
|----------------------------------|--------------------------------|----------|
| 6                                | INDUCTOR TOKO7KMM 220nH        | L4, 7-11 |
| -                                | -                              | -        |
| 1                                | HEADER MOLEX 18WAY LOW PROFILE | P4       |
| 1                                | IC RESET CHIP DS1233 5V        | U14      |
| 1                                | CRYSTAL 4.9152MHz HC49/4       | X1       |

| BOTTOM SIDE CONVENTIONAL COMPONENTS |                                |     |
|-------------------------------------|--------------------------------|-----|
| 1                                   | HEADER MOLEX 8WAY RIGHT-ANGLED | SK1 |

TITLE  
IF RECEIVER - PCB LAYOUT

|  |            |                 |
|--|------------|-----------------|
| DERIVED FROM DRAWING No.<br>4346 - 007 | ISSUE<br>N | SHEET<br>1 of 1 |
|--|------------|-----------------|

D4087-3





Document Number: 83139

October 1998

---

**Printed in England**

Raytheon Marine Company  
676 Island Pond Road  
Manchester  
New Hampshire 03109-5420

Tel: (001 603) 647 7530  
Fax: (001 603) 634 4756

Raytheon Marine Company  
Anchorage Park, Portsmouth  
Hampshire PO3 5TD

Tel: (01705) 693611  
Fax: (01705) 694642  
<http://www.raytheon.com>

**Raytheon**